

Kramer Electronics, Ltd.



USER MANUAL

Rack Adapter Models:

RK-2WP

RK-22WP

RK-121WP

RK-WP16

Contents

1	Introduction	1
2	Getting Started	1
3	Overview	1
3.1	Recommendations for Best Performance	1
4	Your Rack Adapters	2
5	Installing Your Kramer Rack Adapters	2
5.1	Installing Wall Plates on the RK-121WP	3
5.2	Installing Inserts on the RK-WP16	4
6	Technical Specifications	5

Figures

Figure 1: Installing the RK-121WP Rack Adapter	3
Figure 2: Mounting the RK-WP16 Rack Adapter	4

Tables

Table 1: The Wall Plate Rack Adapters	2
Table 2: Rack Adapter Blank Panels – Part Numbers	2
Table 3: Technical Specifications of the Rack Adapters	5

1 Introduction

Welcome to Kramer Electronics! Since 1981, Kramer Electronics has been providing a world of unique, creative, and affordable solutions to the vast range of problems that confront the video, audio, presentation, and broadcasting professional on a daily basis. In recent years, we have redesigned and upgraded most of our line, making the best even better! Our 1,000-plus different models now appear in 11 groups¹ that are clearly defined by function.

Congratulations on purchasing your Kramer **RK-2WP**, **RK-22WP**, **RK-121WP** or **RK-WP16** rack adapters, which are ideal for mounting 1 Gang and 2 Gang wall plates, or wall plate inserts in a 19" 2U rack.

The package includes the following items:

- **RK-2WP**, **RK-22WP**, **RK-121WP** or **RK-WP16** rack adapters
- Additional mechanical parts (blank plates (or inserts), and screws)
- This user manual²

2 Getting Started

We recommend that you:

- Unpack the equipment carefully and save the original box and packaging materials for possible future shipment
- Review the contents of this user manual

3 Overview

You can mount a combination of Kramer 1 Gang and 2 Gang European wall plates, or wall plate inserts in a 19" 2U rack.

3.1 Recommendations for Best Performance

We recommend that you:

- Have a Philips screwdriver available
- Avoid interference from neighboring electrical appliances and position your rack adapter on the rack away from moisture, excessive sunlight and dust



¹ GROUP 1: Distribution Amplifiers; GROUP 2: Switchers and Matrix Switchers; GROUP 3: Control Systems; GROUP 4: Format/Standards Converters; GROUP 5: Range Extenders and Repeaters; GROUP 6: Specialty AV Products; GROUP 7: Scan Converters and Scalers; GROUP 8: Cables and Connectors; GROUP 9: Room Connectivity; GROUP 10: Accessories and Rack Adapters; GROUP 11: Sierra Products

² Download up-to-date Kramer user manuals from the Internet at this URL: <http://www.kramerelectronics.com>

4 Your Rack Adapters

Table 1 defines the different rack adapters:

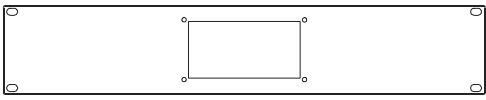
Table 1: The Wall Plate Rack Adapters

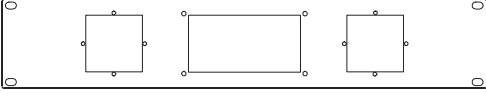
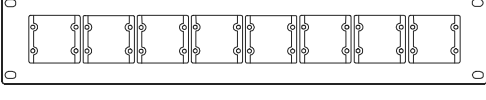
Rack Adapter:	Wall Plates/Inserts	Rack Adapter Diagram
RK-2WP	<ul style="list-style-type: none"> One 2 Gang wall plate 	
RK-22WP	<ul style="list-style-type: none"> Two 2 Gang wall plates 	
RK-121WP	<ul style="list-style-type: none"> One 2 Gang wall plate Two 1 Gang wall plates 	
RK-WP16	<ul style="list-style-type: none"> Up to 16 single wall plate inserts, or Up to 8 double wall plate inserts, or A combination of the above 	

The rack adapters do not have to be entirely full with mounted wall plates (or inserts). You can use blank panels to fill the empty spaces (see Table 2).

Table 2: Rack Adapter Blank Panels – Part Numbers

Rack Adapter	Blank Panel Size	Part Number
RK-2WP	2 Gang (optional)	2732-000432
RK-22WP	2 Gang (1 supplied)	2732-000432
RK-121WP	1 Gang (1 supplied)	2732-000433
	2 Gang (optional)	2732-000432
RK-WP16	Single wall plate Inserts (10 supplied)	2732-503112

5 Installing Your Kramer Rack Adapters

This section describes how to install the:

- **RK-121WP**¹, see section 5.1
- **RK-WP16**, see section 5.2

¹ The RK-2WP and the RK-22WP are mounted in a similar way

5.1 Installing Wall Plates on the RK-121WP

The example in Figure 1 shows how to mount wall plates in the 19" 2U **RK-121WP** rack adapter, including the optional insertion of blank plates.

Use the M3x10 flat-head screws (supplied with the unit) to install the required wall plates on the rack adapter.

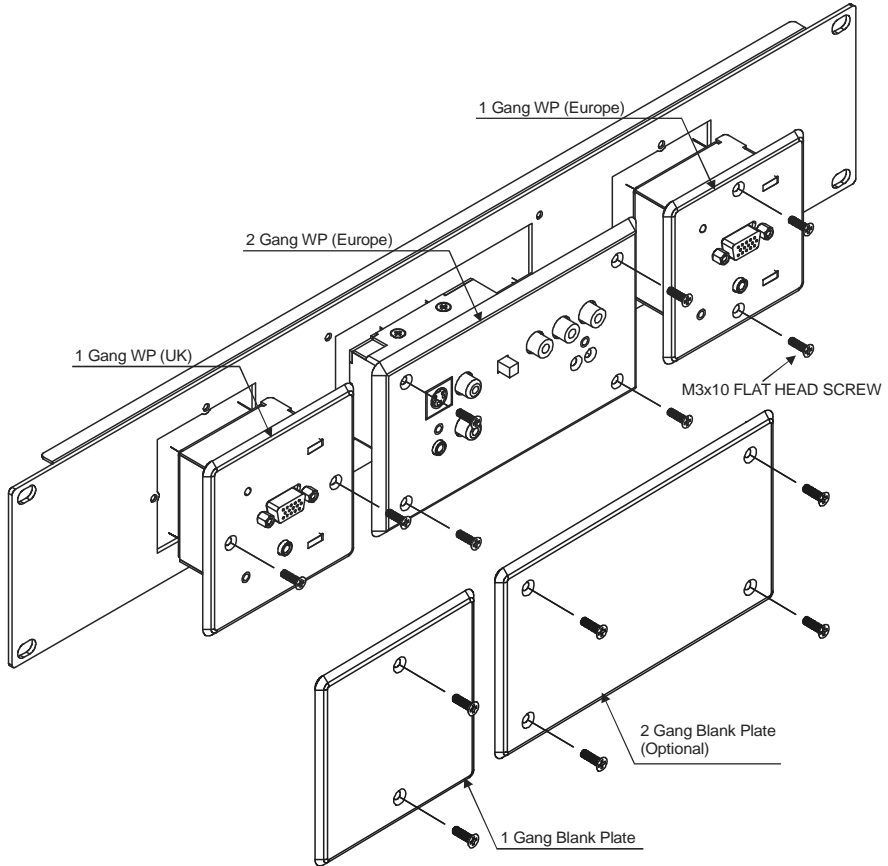

Figure 1: Installing the RK-121WP Rack Adapter

Instead of inserting a wall plate, you can use a blank plate to cover the relevant opening. If required, you can order additional blank plates to cover other openings.

After installing the wall plates, the unit is ready to be mounted on a 19" rack shelf.

5.2 Installing Inserts on the RK-WP16

The example in Figure 2 shows how to mount single and double inserts in the 19" 2U **RK-WP16** rack adapter, including optional insertion of blank inserts.

Use the M3x8 screws (supplied with the unit) to install the required inserts on the rack adapter.

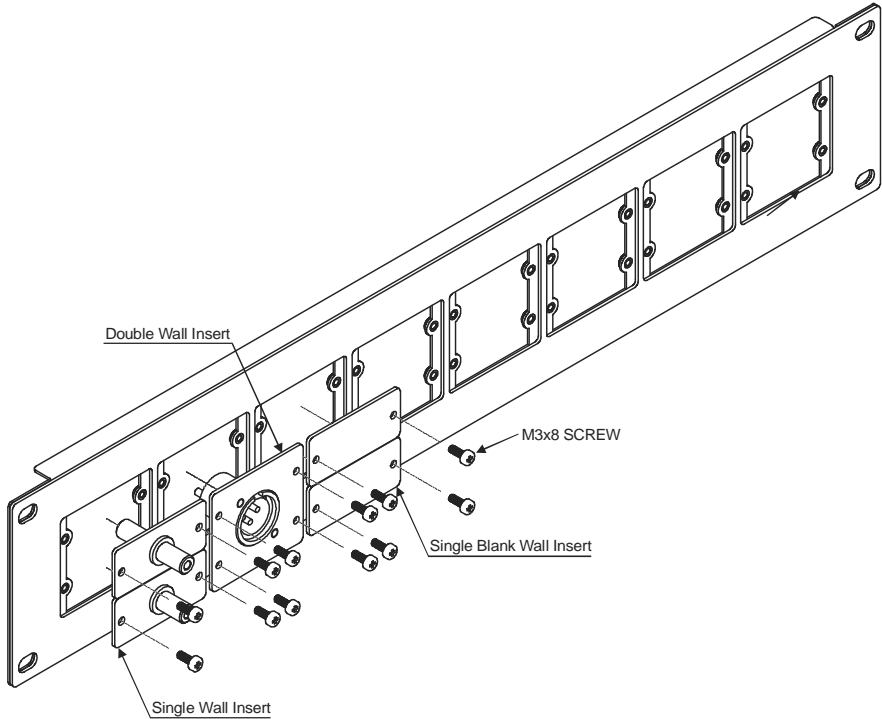

Figure 2: Mounting the RK-WP16 Rack Adapter

Instead of installing an insert, you can use a blank insert to cover the relevant opening. If required, you can order additional blank inserts to cover other openings.

After installing the wall inserts, the unit is ready to be mounted on a 19" rack shelf.

6 Technical Specifications

Table 3 includes the technical specifications:

Table 3: Technical Specifications¹ of the Rack Adapters

DIMENSIONS:	RK-2WP, RK-22WP, RK-121WP: 19-inch (W), 0.39-inch (D) 2U (H) RK-WP16: 19-inch (W), 0.49-inch (D) 2U (H)
WEIGHT:	RK-2WP, RK-22WP, RK-121WP: 0.6kg (1.32lbs) approx. RK-WP16: 0.5kg (1.1lbs) approx.
ACCESSORIES:	RK-2WP: four M3x10 flat screws RK-22WP: eight M3x10 flat screws, one 2 Gang (Europe) blank plate RK-121WP: eight M3x10 flat screws, one 1 Gang (Europe) blank plate RK-WP16: four M3x8 screws, 10 blank inserts
OPTIONS:	Blank plates ²

¹ Specifications are subject to change without notice

² See Table 2

LIMITED WARRANTY

Kramer Electronics (hereafter *Kramer*) warrants this product free from defects in material and workmanship under the following terms.

HOW LONG IS THE WARRANTY

Labor and parts are warranted for seven years from the date of the first customer purchase.

WHO IS PROTECTED?

Only the first purchase customer may enforce this warranty.

WHAT IS COVERED AND WHAT IS NOT COVERED

Except as below, this warranty covers all defects in material or workmanship in this product. The following are not covered by the warranty:

1. Any product which is not distributed by Kramer, or which is not purchased from an authorized Kramer dealer. If you are uncertain as to whether a dealer is authorized, please contact Kramer at one of the agents listed in the Web site www.kramerelectronics.com.
2. Any product, on which the serial number has been defaced, modified or removed, or on which the WARRANTY VOID IF TAMPERED sticker has been torn, reattached, removed or otherwise interfered with.
3. Damage, deterioration or malfunction resulting from:
 - i) Accident, misuse, abuse, neglect, fire, water, lightning or other acts of nature
 - ii) Product modification, or failure to follow instructions supplied with the product
 - iii) Repair or attempted repair by anyone not authorized by Kramer
 - iv) Any shipment of the product (claims must be presented to the carrier)
 - v) Removal or installation of the product
 - vi) Any other cause, which does not relate to a product defect
 - vii) Cartons, equipment enclosures, cables or accessories used in conjunction with the product

WHAT WE WILL PAY FOR AND WHAT WE WILL NOT PAY FOR

We will pay labor and material expenses for covered items. We will not pay for the following:

1. Removal or installations charges.
2. Costs of initial technical adjustments (set-up), including adjustment of user controls or programming. These costs are the responsibility of the Kramer dealer from whom the product was purchased.
3. Shipping charges.

HOW YOU CAN GET WARRANTY SERVICE

1. To obtain service on you product, you must take or ship it prepaid to any authorized Kramer service center.
2. Whenever warranty service is required, the original dated invoice (or a copy) must be presented as proof of warranty coverage, and should be included in any shipment of the product. Please also include in any mailing a contact name, company, address, and a description of the problem(s).
3. For the name of the nearest Kramer authorized service center, consult your authorized dealer.

LIMITATION OF IMPLIED WARRANTIES

All implied warranties, including warranties of merchantability and fitness for a particular purpose, are limited in duration to the length of this warranty.

EXCLUSION OF DAMAGES

The liability of Kramer for any effective products is limited to the repair or replacement of the product at our option. Kramer shall not be liable for:

1. Damage to other property caused by defects in this product, damages based upon inconvenience, loss of use of the product, loss of time, commercial loss; or
2. Any other damages, whether incidental, consequential or otherwise. Some countries may not allow limitations on how long an implied warranty lasts and/or do not allow the exclusion or limitation of incidental or consequential damages, so the above limitations and exclusions may not apply to you.

This warranty gives you specific legal rights, and you may also have other rights, which vary from place to place.

NOTE: All products returned to Kramer for service must have prior approval. This may be obtained from your dealer.

This equipment has been tested to determine compliance with the requirements of:

- EN-50081: "Electromagnetic compatibility (EMC);
generic emission standard.
Part 1: Residential, commercial and light industry"
- EN-50082: "Electromagnetic compatibility (EMC) generic immunity standard.
Part 1: Residential, commercial and light industry environment".
- CFR-47: FCC® Rules and Regulations:
Part 15: "Radio frequency devices
Subpart B Unintentional radiators"

CAUTION!

- ⊗ Servicing the machines can only be done by an authorized Kramer technician. Any user who makes changes or modifications to the unit without the expressed approval of the manufacturer will void user authority to operate the equipment.
- ⊗ Use the supplied DC power supply to feed power to the machine.
- ⊗ Please use recommended interconnection cables to connect the machine to other components.
* FCC and CE approved using STP cable (for twisted pair products)



For the latest information on our products and a list of Kramer distributors, visit our Web site: www.kramerelectronics.com, where updates to this user manual may be found. We welcome your questions, comments and feedback.



Caution

Safety Warning:

Disconnect the unit from the power supply before opening/servicing.



Kramer Electronics, Ltd.

Web site: www.kramerelectronics.com

E-mail: info@kramerel.com

P/N: 2900-000520 REV 1