

cMe2

Installation Guide

Safety

- Fixture installation should be performed in accordance with local and national codes. All fixtures must be properly grounded.
- To prevent fire or electric shock, do not expose the fixtures to water or moisture. cMe2 fixtures are listed for indoor use only.
- A qualified technician should perform service on fixtures. Do not remove the driver cover until the unit has been de-energized.

Owner's Record

The model and serial number of this product can be found on the side of the fixture's main housing. You should note the model number and the serial number in the space provided and retain this book for future reference as a permanent record of your purchase.

Model #: _____

Serial #: _____

Date of Purchase: _____

Product Description

The Brightline cMe2 is a single channel, LED videoconferencing fixture that may be desk or wall mounted. These fixtures combine high-frequency electronics with a state-of-the-art optical system to produce a soft, full-spectrum, flicker-free light source.

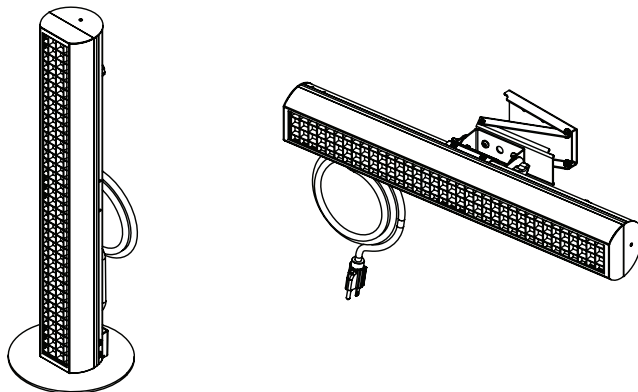

580 Mayer Street - Building # 7 - Bridgeville, PA 15017 USA

Phone: 1.412.206.0106

www.brightlines.com

Housing

20-gauge (0.036-in) formed, cold-rolled steel sheet metal construction, plastic cover and louver

Heat sink

6063-T5 Aluminum Extrusion

LED Drivers (integral drivers)

Control: 0-10V

Input: 120V 60Hz

Output: 48V, 0.30A, 33W

Color Temperature

3500K: 36,000 hours - 90CRI

Finish

Low-glare, polyester powder coat, RAL 9005 Jet Black, Satin Finish

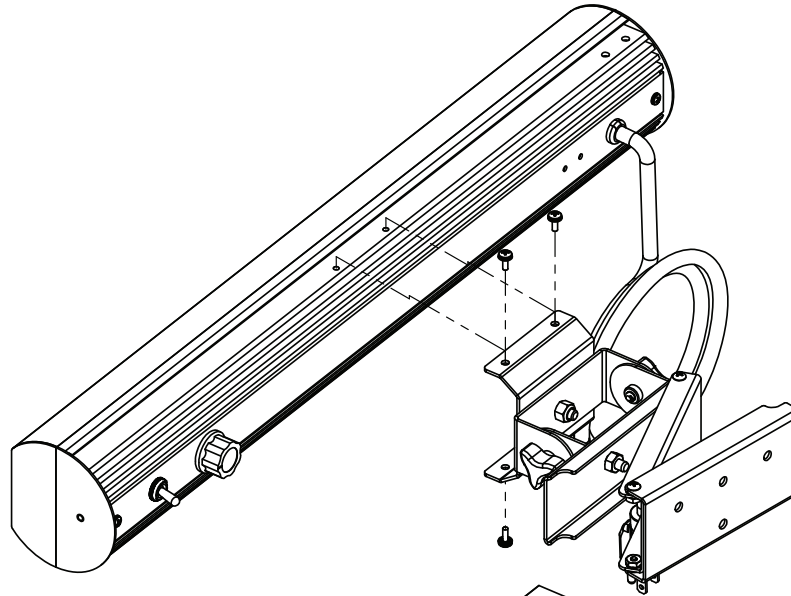

ADHESIVE BACKED CORD
CLIP TO CENTER POWER CORD
INSTALLED AFTER FIXURE IS MOUNTED

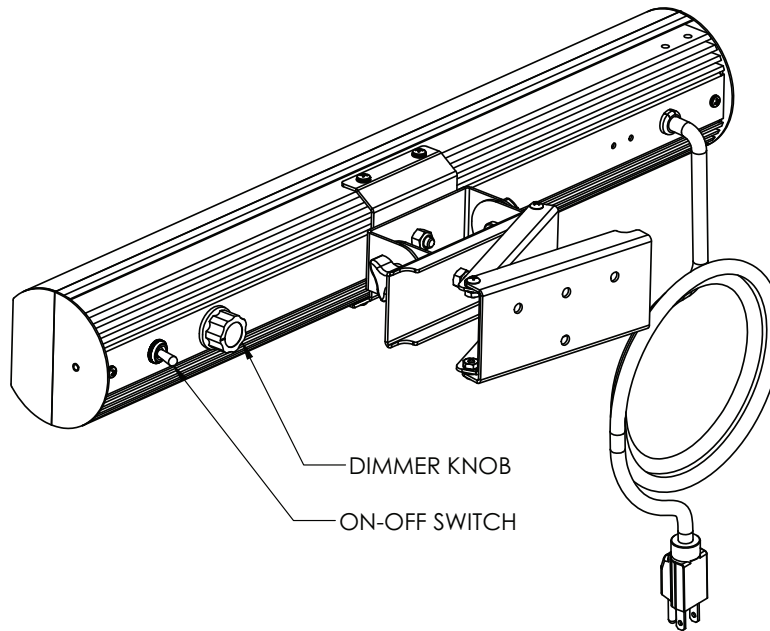

580 Mayer Street - Building # 7 - Bridgeville, PA 15017 USA

Phone: 1.412.206.0106

www.brightlines.com

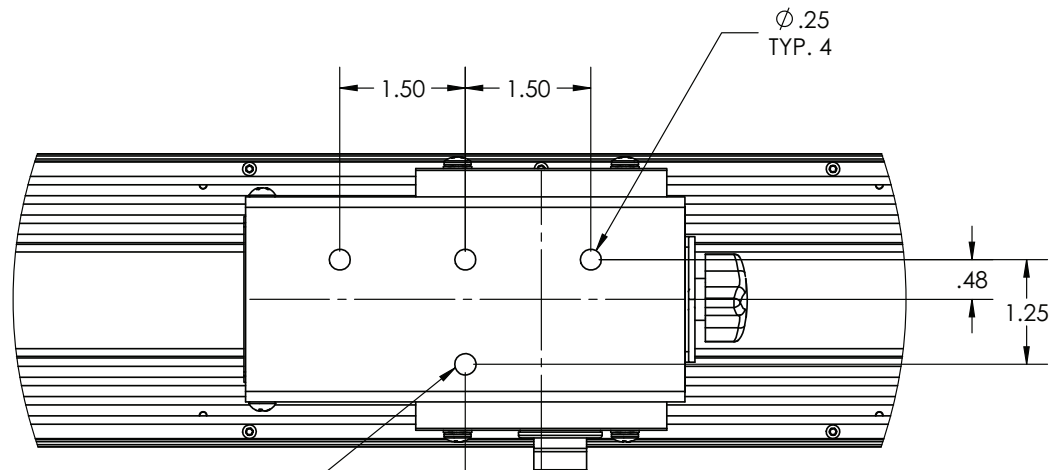
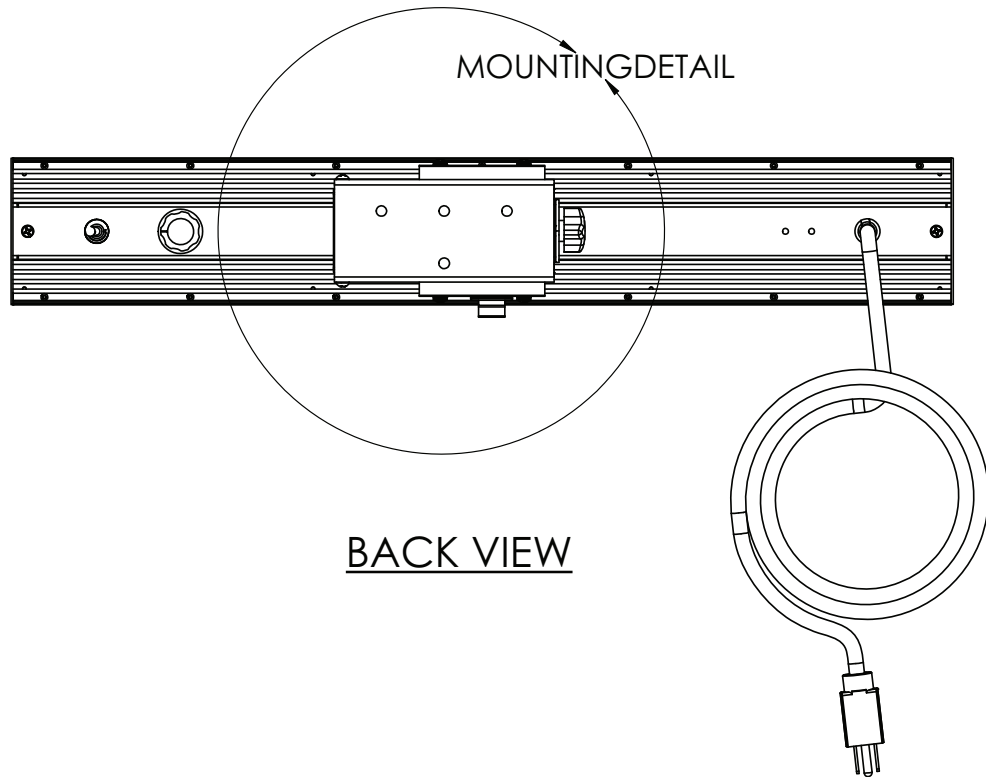

NOTE: CENTER LINE OF FIXTURE IS OFFSET FROM CENTER LINE OF MOUNTING BRACKET BY .91"

MOUNTING DETAIL

(MOUNTING HARDWARE BY OTHERS)

580 Mayer Street - Building # 7 - Bridgeville, PA 15017 USA

Phone: 1.412.206.0106

www.brightlines.com



brightline[®]

© 2019 Brightline LP. All Rights Reserved

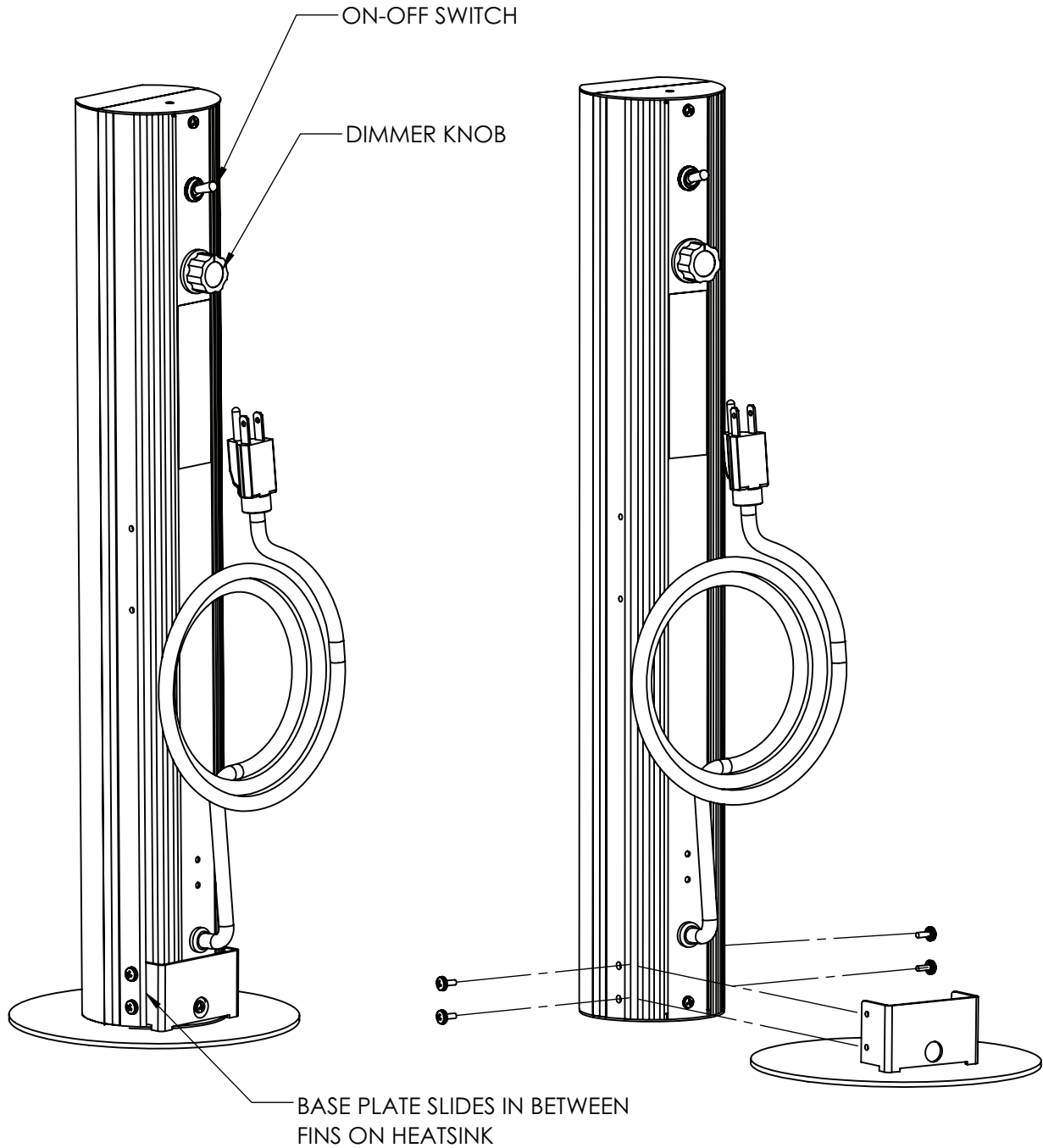

580 Mayer Street - Building # 7 - Bridgeville, PA 15017 USA

Phone: 1.412.206.0106

www.brightlines.com



brightline[®]

© 2019 Brightline LP. All Rights Reserved



Brightline guarantees all its manufactured LED products to be free from defects in materials and workmanship for a period of three (3) years from the date of shipment.

PROCEDURES

If any product is found to be unsatisfactory under this warranty, the buyer must notify **Brightline** immediately. Once a course of action has been determined, if it is necessary to return the product to **Brightline** a Return Authorization (RA) will be issued. Ship the product directly to **Brightline**, 580 Mayer Street, Building #7, Bridgeville, PA 15017. The RA number should be marked on the shipping carton. The unit will be replaced or put into proper operating condition, free of all charges. The correction of any defects through repair or replacement by **Brightline** shall constitute fulfillment of all obligations and liability of **Brightline** to the buyer under this warranty and the contract of sale.

DISCLAIMERS

Brightline is not responsible for damage to its products caused by improper installation, maintenance, or use; by improper electrical hookups; or by unauthorized repairs.

Failure to notify **Brightline** of unsatisfactory operation or any improper or unauthorized installation, maintenance, use, repairs, or adjustments shall terminate the warranty and **Brightline** shall have no further responsibility under the warranty.

Brightline shall not be liable for special or consequential damages in any claim, action, suit, or proceeding arising under this warranty or contract of sale, nor shall **Brightline** be liable for claims for labor, loss of profits or goodwill, repairs, or other expenses incidental to replacement. **Brightline** makes no other warranty of any kind whatsoever, expressed or implied, and all implied warranties of merchantability and fitness for a particular purpose that exceed the obligation specifically described in this warranty are hereby disclaimed by **Brightline** and excluded from this agreement.

All shipments, unless otherwise noted, are F.O.B. factory.

The customer is advised to inspect for shipping damage, apparent and/or hidden.

If detected, notify the transportation company and file your claim.

580 Mayer Street - Building # 7 - Bridgeville, PA 15017 USA

Phone: 1.412.206.0106

www.brightlines.com



© 2019 Brightline LP All Rights Reserved