



Kramer Electronics, Ltd.

USER MANUAL

VGA/XGA/Audio Switchers

Models:

VP-61N

VP-61*xl*

IMPORTANT: Before proceeding, please read paragraph entitled
"Unpacking and Contents"



Table Of Contents

Section	Name	Page
1	INTRODUCTION	2
1.1	A Word on VGA/XGA/Audio Switchers	2
1.2	Handling Graphics Signals	2
1.3	Factors Affecting Quality of Results	2
2	HOW DO I GET STARTED	5
3	UNPACKING AND CONTENTS	5
3.1	Optional Accessories	5
4	VGA/XGA/AUDIO SWITCHER	6
4.1	Getting to know your VP 61xl Switcher	7
5	INSTALLATION	8
5.1	Rack Mounting	8
6	CONNECTING TO VGA/XGA/DEVICES	8
7	CONNECTING TO AUDIO DEVICES	8
8	USING THE SWITCHER	8
8.1	Powering UP the Switcher	8
8.2	Selecting an Input on the Switcher	8
8.3	Controlling the VP 61xl	9
8.3.1	DIP Switches	9
8.3.2	The "Reply" option	9
9	CONNECTING TO A PC	10
9.1	PC Control Software	11
10	SPECIFICATIONS	11
11	TROUBLESHOOTING	11
11.1	Power and Indicators	12
11.2	VGA/XGA Signal	12
11.3	Audio Signal	12
	Limited Warranty	13

List Of Illustrations

Figure	Description	Page
1	VP 61xl Front/Rear Panel Features	7
2	RS 232 Control Connector Wiring	10
3	Connecting Multi Machines	10

List Of Tables

Table	Description	Page
1	VP 61xl Front/Rear Panel Features	7
2	DIP Switch settings	9



1 INTRODUCTION

Congratulations on your purchase of this Kramer switcher. Since 1981, Kramer has been dedicated to the development and manufacture of high quality video/audio equipment. The Kramer line has become an integral part of many of the best production and presentation facilities around the world. In recent years, Kramer has redesigned and upgraded most of the line, making the best even better. Kramer's line of professional video/audio electronics is one of the most versatile and complete available, and is a true leader in terms of quality, workmanship, price/performance ratio and innovation. In addition to the Kramer line of high quality switcher, such as the one you have just purchased, Kramer also offers a full line of high quality distribution amplifiers, processors, interfaces, controllers and computer-related products. This manual includes configuration, operation and option information for the **VP-61xl** VGA/XGA/Audio switcher. The **VP-61N** is identical to the **VP-61xl** but it does not include the audio channels.

1.1 A Word on VGA/XGA/Audio Switchers

VGA/XGA/Audio Switchers route signals to one or more selected users. They vary in the number of inputs, looping capability, programming capability, number of outputs, operating format, bandwidth and input/output coupling. VGA/XGA/Audio Switchers are used to select which source is to be switched to which acceptor for recording or monitoring, with no discernible signal degradation. A good quality VGA/XGA/Audio Switcher amplifies the incoming signal, pre-compensates the signal for potential losses (resulting from the use of long cables, noisy source, etc.) and routes the signal(s) to buffered and amplified outputs. Often, a signal processor is inserted between the source and the VGA/XGA/Audio switcher for correction and fine-tuning of the source signal before routing. The front panel of this Kramer switcher is designed to be simple to operate. The machine described in this manual switches one of several PC's to a monitor. It is RS232 controlled for remote PC operation. It excels in high source isolation for minimal crosstalk and very large bandwidth.

1.2 Handling Graphics Signals

A computer generated graphics signal is usually comprised of 5 signals: Red, Green, Blue -which are analog level signals and two TTL (logic) level signals - Horizontal Sync and Vertical Sync. (Digital graphics cards and monitors use a different signal format, and will not be discussed here, as they are not relevant.) Computer graphics resolution is measured in pixels and signal bandwidth. The more pixels (picture elements) on the screen, the more detailed the image. VGA, S-VGA, XGA, S-XGA and U-XGA are terms describing the graphics resolution and the color depth. Color depth represents the maximum number of

simultaneously displayed colors on the screen and is measured in bits. 24 and 32-36 bits of color depth represent millions to billions of color shades available on the screen at any given moment. (It should be born in mind, though, that the human eye can resolve only a few thousands colors!) The more detailed the image (higher resolution) and the higher the color depth the more real the image will look. The highest resolution of standard VGA was 640x480 pixels with 4 bits of color (16 colors). The standard VGA was able to use more colors (256) but at a lower resolution, around 320x200 pixels, which was very crude. Common resolutions used nowadays for computer graphics vary from 1024x768 up to 2000x1600 pixels with “high color” - 16 bits of color, representing 64,000 different colors, up to “true color” - 24 bits or more, representing from 16.7 million colors up to several billion. Displaying such a detailed and colorful image on the screen needs enormous graphics memory per frame, as well as very high speeds for “writing” so many pixels on the screen in real time. The amplifiers that carry those signals must be able to handle those speeds and hence signal bandwidth.

The standard VGA at 640x480 resolution needed amplifiers with 20-30MHz bandwidth. At 1600x1200 or even at 1280x1024 (S-XGA), those amplifiers will fail completely. In order to faithfully amplify and transmit modern high-resolution graphics, amplifiers with bandwidths of 300 MHz and more are needed. Those amplifiers, besides the enormous bandwidth they handle, need to be linear, to have very low distortion and be stable. Stability of an amplifier is its ability to avoid bursting into uncontrolled oscillation, which is in adverse relationship to the speed it can handle. The tendency to oscillate is further enhanced by the load impedance. The load impedance of a system is usually not just a resistor. A cable connected to an amplifier (leading to the receiver or monitor) may present a capacitive and/or an inductive load to the amplifier. This is the main cause of instability. The quality problems of a load or cable may severely degrade the bandwidth, linearity, and stability of the amplifier and in general its ability to faithfully reproduce the signal.

Cables affect image resolution. Longer cables, due to imperfect characteristics, cause high frequency deterioration and hence image “smear” and loss of resolution. In computer graphics especially, this adverse effect is very much accentuated. The amplifiers should therefore cope with an additional task - compensating for cable losses up to the maximum useful operation distance. High-resolution graphics systems should use very high quality cables for image transmission. The cables should be shielded to eliminate externally induced interference but the shield might itself increase the capacitance of the cable, and therefore, cause deterioration in the image’s resolution and clarity. Standard quality cables can only be a few meters long. For longer distances, the compound

cable is replaced by five individual coax cables, which are bulky and cumbersome for use. Even then, the distance is limited to several tens of meters. The imperfect behavior of a cable may create other problems resulting from its failure to accurately match the system's required impedance. The result of this, especially at high frequencies, is "shadows" or "ghosts" on the image, resulting from standing waves and electronic reflections running back and forth between transmitter and receiver. Another aspect to consider is the sync. As sync signals are logic signals, which are not treated as analog signals, the receiver does not terminate the line, and therefore the line is not matched. A host of problems can occur when sync signals are sent over long, unterminated, unmatched cables. The result might be image breakdown or distortion due to improper sync information. The amplifier that drives the analog section of the graphics data should also be able to buffer, recover and send the sync information in such a way that it is received properly at the receiving end.

1.3 Factors Affecting Quality of Results

There are many factors affecting the quality of results when signals are transmitted from a source to an acceptor:

- ⊗ **Connection cables** - Low quality cables are susceptible to interference; they degrade signal quality due to poor matching and cause elevated noise levels. They should be of the best quality.
- ⊗ **Sockets and connectors of the sources and acceptors** - So often ignored, they should be of highest quality, since "Zero Ohm" connection resistance is the target. Sockets and connectors must also match the required impedance (75ohm in video). Cheap, low quality connectors tend to rust, thus causing breaks in the signal path.
- ⊗ **Amplifying circuitry** - Must provide quality performance when the desired end result is high linearity, low distortion and low noise operation.
- ⊗ **Distance between sources and acceptors** - Plays a major role in the final result. For long distances of over 15 meters (~2 to 3 meters for VGA/XGA) between sources and acceptors, special measures should be taken in order to avoid cable losses. These include using higher quality cables or adding line amplifiers.
- ⊗ **Interference from neighboring electrical appliances** - They can have an adverse effect on signal quality. Balanced audio lines are less prone to interference, but unbalanced audio should be installed far from any mains power cables, electric motors, transmitters, etc. even when the cables are shielded.



2 HOW DO I GET STARTED?

The fastest way to get started is to take your time and do everything right the first time. Taking 15 minutes to read the manual may save you a few hours later. You don't even have to read the whole manual. If a section doesn't apply to you, you don't have to spend your time reading it.

3 UNPACKING AND CONTENTS

The items contained in your Kramer switcher package are listed below. Please save the original box and packaging materials for possible future shipment.

- ☒ Switcher
- ☒ AC power cable
- ☒ This User Manual
- ☒ KRAMER Software for Windows 95/98 ®
- ☒ KRAMER Null Modem Adapter Connector
- ☒ Kramer concise product catalog/CD
- ☒ Rubber feet

3.1 Optional Accessories

The following accessories, which are available from Kramer, can enhance implementation of your machine. For information regarding cables and additional accessories, contact your Kramer dealer.

- ☐ **VP-300** - (1:3 High Resolution VGA Distribution Amplifier) can be serially inserted between the switcher and the acceptors. It is a full bandwidth distributor designed for computer and workstations applications. The **VP-300** splits a VGA/Super-VGA/XGA graphics card output to 3 monitors, with no discernible signal degradation. State-of-the-art video amplifying circuitry and microchip technology make the **VP-300** the first choice Graphics Component Distributor. Signal bandwidth of 345MHz allows the **VP-300** to be used with the highest quality graphics workstations.
- ☐ **VP-211** - (2x1 Automatic VGA/Audio Switcher) can be serially inserted between the VGA/audio switcher and the acceptors for VGA/audio distribution. It is a full bandwidth switcher designed for computer and presentation applications. The **VP-211** automatically detects the presence of a VGA/XGA signal on input no. 1 and routes it to the output. If the signal disappears, the machine switches to input no. 2 and routes it to the output. When the signal on input no. 1 re-appears, the **VP-211** reroutes input no. 1 to the output. The machine operates in audio-follow-video (VGA) mode and

switches the stereo audio input appropriate to the VGA input. Signal bandwidth of 517MHz ensures that the **VP-211** remains transparent even in the most critical applications. The **VP-211** is part of the Kramer TOOLS family of compact, high quality and cost effective solutions for a variety of applications.

- **VP-22** - (VGA / XGA Line Amplifier & Processor) can be serially inserted between the VGA switcher and the acceptors for signal processing. It is a full bandwidth machine designed for computer and workstation applications where remote monitoring is needed. The **VP-22** splits a VGA/Super VGA/XGA graphics card output to 2 remote monitors and allows the user to control signal level and cable equalization for each channel independently. The machine also allows control of horizontal and vertical sync delay on the BNC coaxial outputs. On its H/HV SYNC output BNC, the **VP-22** allows either horizontal or composite sync while on its green output BNC, it allows either green or green + composite sync. State-of-the-art video amplifying circuitry makes the **VP-22** the perfect graphics component amplifier. Signal bandwidth of over 350MHz allows it to be used with the highest quality graphics workstations.

- **VP-102** - (VGA to RGBS Converter) can be serially inserted between the VGA switcher and the acceptors for VGA to RGBS conversion. It is a full bandwidth machine especially designed for computer, workstation and presentation applications. The **VP-102** converts a VGA/Super - VGA/XGA graphics card output to red, green, blue, horizontal/composite sync and vertical sync signals available on BNC connectors. The **VP-102** allows the user to select either a composite or horizontal sync output and the green output either includes composite sync or is blanked. The composite sync generated by the machine is always at the correct polarity (negative), for any polarity of Hs and Vs inputs. As the signal bandwidth is well over 315MHz, the **VP-102** may be used with the highest quality graphics workstations.

4 VGA/XGA/AUDIO SWITCHER

This section describes the controls and connections of your switcher. Understanding the controls and connections helps you realize the full power of your machine. Please note that only the **VP-61xl** is described below, but all the functions and features, besides the audio section, are identical for the **VP-61N**.

4.1 Getting to Know Your VP-61xl Switcher

The Kramer **VP-61xl** is a 6x1 switcher for VGA/XGA and Balanced Stereo Audio signals. It is designed to route one of up to six inputs to one output using 15pin HD female connectors for the VGA/XGA signals, and detachable terminal block connectors for audio. Bandwidth exceeding 400MHz ensures transparent VGA/XGA performance. The inputs and output are directly coupled, and conform to the highest standards. The **VP-61xl** can be controlled by front panel switches, or remotely by RS-232 serial commands transmitted by a touch screen system, personal computer, or other serial control device. It is housed in a rugged, professional rack mountable enclosure.

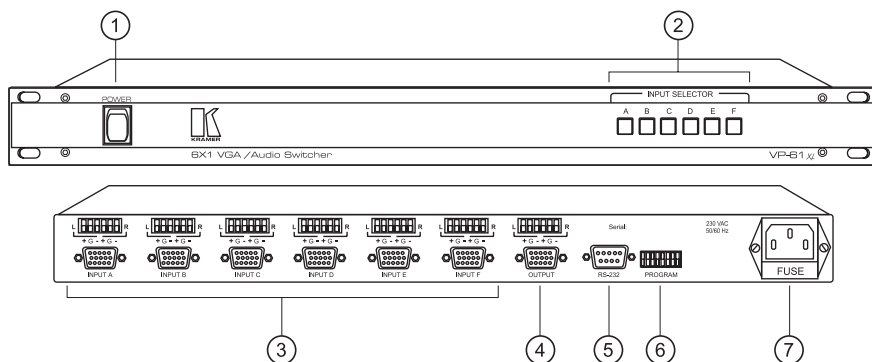

Figure 1: VP-61xl Front/Rear Panel Features

Table 1: VP-61xl Front/Rear Panel Features

No.	Feature	Function
1	Illuminated power switch	Supplies power to the unit.
2	INPUT SELECTOR switches	Select the desired input to be switched.
3	INPUT A-F connectors	6 VGA/XGA/Balanced Audio inputs.
4	OUTPUT Connectors	VGA/XGA/Balanced Audio output.
5	RS-232 (DB 9 female connector)	Used for control of the switcher from a PC through an RS 232 interface.
6	PROGRAM Dip Switches	Allow proper configuration of the RS 232 control signals.
7	Power connector	A 3 prong AC connector allows power to be supplied to the unit. The fuse is located in the connector.



5 INSTALLATION

5.1 Rack Mounting

The **VP-61xl** switcher may be rackmounted in a standard 19" (1U) EIA rack assembly, and includes rack "ears" at the ends of the front panel. The machine does not require any specific spacing above or below the unit for ventilation. To mount the switcher, simply place the rack ears against the rails of your rack, and insert standard screws through each of the four corner holes in the front panel.

6 CONNECTING TO VGA/XGA DEVICES

Video sources and output devices (such as monitors, projectors or recorders) may be connected to the switchers through the HD 15F connectors located on the back of the unit. Unused inputs are terminated to 75 Ohm, and active inputs should be terminated by the connecting source.

7 CONNECTING TO AUDIO DEVICES (VP-61XL ONLY)

Audio sources and output devices may be connected to the switcher through the terminal block connectors located on the back of the unit. The machine allows for balanced stereo audio switching. If Unbalanced stereo is used, the (-) input pin should be connected to the ground pin, and the (+) pin is used for the signal input.

8 USING THE SWITCHER

8.1 Powering on the Switcher

Notes:

The switcher should only be powered on after all connections are completed and all source devices have been powered on. Do not attempt to connect or disconnect any video, audio or control signals to the switcher while it is powered on!

The socket-outlet should be near the equipment and should be easily accessible. To fully disconnect equipment, remove power cord from its socket after it has been turned off.

1. Press the toggle switch on the far-left front panel to the up position. In the up position, the toggle switch glows and the active input button illuminates, as well.
2. Operate the acceptors.

8.2 Selecting an Input on the Switcher

Input selection is simply made by pressing the front panel buttons marked "A", "B", "C", etc. or via your PC. The buttons correspond to the input connections as marked on the back panel.

8.3 Controlling the VP-61xl

The **VP-61xl** switcher can be controlled by the following methods:

1. By touch buttons on the front panel.
2. By any RS-232 controller such as a PC.

8.3.1 DIP Switches

The **VP-61xl** selects one of 6 VGA/XGA/Audio sources.

The DIP switch (see Table 2) on the rear panel is used when the switcher is operated via the RS-232 connector or when it is interconnected with other switchers. These switches allow proper configuration of the control signals received/transmitted through the RS-232 control port. The **VP-61xl** allows master/slave configurations so that the switchers may operate independently, or in conjunction with each other.

Table 2: DIP Switch Settings

Machine #	PROGRAM				ADDRESS			
	1	2	3	4	5	6	7	8
1 (Master)	ON	OFF	ON	ON	OFF	OFF	OFF	OFF
2 (Slave)	OFF	OFF	OFF	ON	OFF	OFF	OFF	ON
3 (Slave)	OFF	OFF	OFF	ON	OFF	OFF	ON	OFF
4 (Slave)	OFF	OFF	OFF	ON	OFF	OFF	ON	ON
5 (Slave)	OFF	OFF	OFF	ON	OFF	ON	OFF	OFF
6 (Slave)	OFF	OFF	OFF	ON	OFF	ON	OFF	ON
7 (Slave)	OFF	OFF	OFF	ON	OFF	ON	ON	OFF
8 (Slave)	OFF	OFF	OFF	ON	OFF	ON	ON	ON

Legend:

Switches 1, 2, 3: RS232

Switch 4: Reply

Switch 5: Baud Rate (Off=1200, On=9600 Baud)

Switches 6, 7, 8: ADDRESS

8.3.2 The "Reply" Option

When the PC addresses the Master/Slave machines, a "Reply" signal is sent back to the PC indicating that the instruction was received by the addressed machine. When several machines are connected in parallel (all with the same machine number), it is not possible for all of them to transmit at the same time. Therefore, only the Master machine replies (switch 4 is enabled).

Note:

The Slave "Reply" settings are all ON or all OFF, depending on the requirements of the system. The Master "Reply" setting is always ON.

9 CONNECTING TO A PC

To connect directly to a PC use the KRAMER Null-Modem Adapter (recommended) plug one end into the PC's serial port, then connect a 9-pin flat-cable from the other end to the switcher. To connect without using the KRAMER Adapter, make connections as in Figure 2, When multi-machines are to be connected together, make the connections as in Figure 3, or extend pins "5" and "9" only.

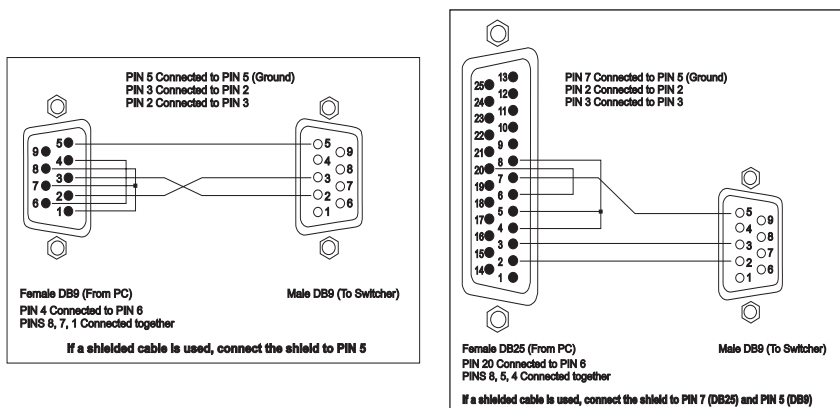

Figure 2: RS-232 Control Connector Wiring

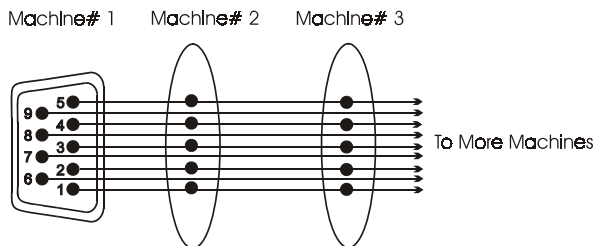

Figure 3: Connecting Multi-Machines

9.1 PC Control Software

If needed, install the PC software which is provided either on diskettes or on a CD and follow the instructions. The software and upgrades are also available at Kramer's website: www.kramerelectronics.com at the technical support section. The RS-232 communication protocol may also be found on the diskettes or CD provided or on the website.

10 SPECIFICATIONS

INPUTS:	6 Analog Red, Green, Blue signals - 0.7 Vpp/75 Ω , H & V syncs, TTL level on HD15F connectors. 6 Balanced Audio Stereo signals, +4dBm typical, 24dBm max. on detachable terminal blocks (VP-61xl only).
OUTPUT:	One Analog Red, Green, Blue signal - 0.7 Vpp/75 Ω , H & V syncs, TTL level on a HD15F connector. One Balanced Audio Stereo signal, +4dBm typical, 24dBm max. on a detachable terminal block (VP-61xl only).
VIDEO BANDWIDTH:	>400 MHz -3dB.
SWITCH TIME:	Less than 5ms.
SWITCH CONTROL:	Six electronic illuminated touch switches with electronic interlock. RS-232 via an additional DB-9 connector on rear panel.
COUPLING:	Direct.
DIMENSIONS:	19 inch (W), 7 inch (D) 1U (H) rack mountable.
POWER SOURCE:	230 VAC, 50/60 Hz, (115VAC, U.S.A.) 3 VA.
WEIGHT:	2.7 kg. (6 lbs.) approx.
ACCESSORIES:	Power cord, Windows TM control software.

11 TROUBLESHOOTING

NOTES

Please note that if the output signal is disturbed or interrupted by very strong external electromagnetic interference, it should return and stabilize when such interference ends. If not, turn the power switch off and on again to reset the machine.

If the following recommended actions do not result in satisfactory operation, please consult your KRAMER dealer.

11.1 Power and Indicators

Problem	Remedy
No Power	<ol style="list-style-type: none"> 1. Confirm that power connections are secured at the machine and at the receptacle. Make sure the receptacle is active, outputting the proper voltage. 2. If still there is no power, remove power cord from AC outlet and then using a flat head screwdriver, remove the fuse holder located directly below the power connector on your switcher. 3. Confirm that the fuse is good by looking for the wire connected between the ends of the fuse. If the wire is broken, replace the fuse with another, with the same rating.

11.2 VGA/XGA Signal

Problem	Remedy
No signal at the output device	<ol style="list-style-type: none"> 1. Confirm that your sources and output device are powered on and connected properly. 2. Confirm that any other device in the signal path have the proper input and/or output selected.

11.3 Audio Signal (VP-61xl only)

Problem	Remedy
No audio at the output device, regardless of input selected	<ol style="list-style-type: none"> 1. Confirm that your sources and output device are powered on and connected properly. 2. Confirm that any other amplifiers in the signal path have the proper input and/or output selected. Pay special attention to input amplifiers that may be built into your acceptor.
Audio level is too low	<ol style="list-style-type: none"> 3. Confirm that the connecting cables are of high quality and properly built. 4. Check level controls located on your source input device or output display or recorder.



LIMITED WARRANTY

Kramer Electronics (hereafter Kramer) warrants this product free from defects in material and workmanship under the following terms.

HOW LONG IS THE WARRANTY

Labor and parts are warranted for three years from the date of the first customer purchase.

WHO IS PROTECTED

Only the first purchase customer may enforce this warranty.

WHAT IS COVERED AND WHAT IS NOT COVERED

Except as below, this warranty covers all defects in material or workmanship in this product. The following are not covered by the warranty:

- 1) Any product which is not distributed by Kramer, or which is not purchased from an authorized Kramer dealer. If you are uncertain as to whether a dealer is authorized, please contact Kramer at one of the agents listed in the web site www.kramerelectronics.com.
- 2) Any product, on which the serial number has been defaced, modified or removed.
- 3) Damage, deterioration or malfunction resulting from:
 - a) Accident, misuse, abuse, neglect, fire, water, lightning or other acts of nature.
 - b) Product modification, or failure to follow instructions supplied with the product.
 - c) Repair or attempted repair by anyone not authorized by Kramer.
 - d) Any shipment of the product (claims must be presented to the carrier).
 - e) Removal or installation of the product.
 - f) Any other cause, which does not relate to a product defect.
 - g) Cartons, equipment enclosures, cables or accessories used in conjunction with the product.

WHAT WE WILL PAY FOR AND WHAT WE WILL NOT PAY FOR

We will pay labor and material expenses for covered items. We will not pay for the following:

- 1) Removal or installations charges.
- 2) Costs of initial technical adjustments (set up), including adjustment of user controls or programming. These costs are the responsibility of the Kramer dealer from whom the product was purchased.
- 3) Shipping charges.

HOW YOU CAN GET WARRANTY SERVICE

- 1) To obtain service on you product, you must take or ship it prepaid to any authorized Kramer service center.
- 2) Whenever warranty service is required, the original dated invoice (or a copy) must be presented as proof of warranty coverage, and should be included in any



shipment of the product. Please also include in any mailing a contact name, company, address, and a description of the problem(s).

- 3) For the name of the nearest Kramer authorized service center, consult your authorized dealer.

LIMITATION OF IMPLIED WARRANTIES

All implied warranties, including warranties of merchantability and fitness for a particular purpose, are limited in duration to the length of this warranty.

EXCLUSION OF DAMAGES

Kramer's liability for any defective products is limited to the repair or replacement of the product at our option. Kramer shall not be liable for:

- 1) Damage to other property caused by defects in this product, damages based upon inconvenience, loss of use of the product, loss of time, commercial loss; or:
- 2) Any other damages, whether incidental, consequential or otherwise. Some countries may not allow limitations on how long an implied warranty lasts and/or do not allow the exclusion or limitation of incidental or consequential damages, so the above limitations and exclusions may not apply to you.

This warranty gives you specific legal rights, and you may also have other rights, which vary from place to place.

NOTE: All products returned to Kramer for service must have prior approval. This may be obtained from your dealer.

NOTICE

This equipment has been tested to determine compliance with the requirements of:

EN-50081: "Electromagnetic compatibility (EMC);
generic emission standard.

Part 1: Residential, commercial and light industry"

EN-50082: "Electromagnetic compatibility (EMC) generic immunity standard.
Part 1: Residential, commercial and light industry environment".

CFR-47 FCC Rules and Regulations:

Part 15 "Radio frequency devices:

Subpart B Unintentional radiators"

CAUTION!

- ⊗ Servicing the machines can only be done by an authorized Kramer technician. Any user who makes changes or modifications to the unit without the expressed approval of the manufacturer will void user authority to operate the equipment.
- ⊗ Use the supplied DC power supply to feed power to the machine.
- ⊗ Please use recommended interconnection cables to connect the machine to other components.



**The list of Kramer distributors appears on our web site:
www.kramerelectronics.com**

**From the web site it is also possible to e-mail factory headquarters.
We welcome your questions, comments and feedback.**

Kramer Electronics Ltd.

3 Am VeOlamo Street. Jerusalem 95463, Israel Tel: (972 2) 654 4000.
Fax: (972 2) 653 5369, E mail: kramerel@netvision.net.il