

R2-SERIES

INSTALLATION / OPERATION MANUAL



Weather-Resistant, High-Fidelity,
Full-Range Loudspeaker Systems



EC STATEMENT OF CONFORMITY

EC STATEMENT OF CONFORMITY

This document confirms that the range of products of Community Professional Loudspeakers bearing the CE label meets all of the requirements in the EMC directive 89/336/EEC laid down by the Member States Council for adjustment of legal requirements. Furthermore, the products comply with the rules and regulations referring to the electromagnetic compatibility of devices from 30-August-1995.

The Community Professional Loudspeaker products bearing the CE label comply with the following harmonized or national standards:

DIN EN 55013:08-1991

DIN EN 55020:05-1995

DIN EN 55082-1:03-1993

The authorized declaration and compatibility certification resides with the manufacturer and can be viewed upon request. The responsible manufacturer is the company:

Community Light & Sound
333 East Fifth Street
Chester, PA 19013
USA

TEL: 1-(610) 876-3400
FAX: 1-(610) 874-0190

FIND THE LATEST ONLINE

Every effort has been made to ensure that the information contained in this manual was complete and accurate at the time of printing. However, due to ongoing technical advances, changes or modifications may have occurred that are not covered in this publication. The latest version of this manual and the most recent product information published by Community is always available at <http://www.communitypro.com> on the world wide web. The publication date can be found on the rear cover or last page.

WELCOME TO COMMUNITY

A TRADITION OF EXCELLENCE AND INNOVATION

Since the founding of our company in 1968, Community has been a constant developer and innovator of loudspeaker technology. Many of our engineering achievements were undertaken to solve problems, when no prior solutions existed. Others resulted from simply seeing a better way to do things.

Over the years our technologies have been imitated, and our methods have become common practice throughout the professional sound industry. However, developments like carbon fiber diaphragm compression drivers still stand alone, and well ahead of the competition. Just a few of Community's unique accomplishments include the following:

- First successful fiberglass mid, high frequency, and large-format bass horns.
- First compression loaded mid-range horn for touring systems - the LMF.
- First suspension-less diaphragm HF driver - the VHF100.
- First mid-range, full-decade (200 Hz - 2 kHz) high-power compression driver - the M4.
- First carbon fiber diaphragm compression drivers - M4, EM280, EM282.
- First Ferrofluid-cooled professional woofers - the VBS Series.
- First product series with all drivers Ferrofluid-cooled.
- First air-cooled loudspeakers for touring systems - AirForce.
- First three-way cinema loudspeaker systems - Paramount Executive Studio Theatre, Warner Bros. screening theatre and dubbing rooms.
- First electro-acoustic system to equal the sound level of pneumatic warning sirens.
- First to provide loudspeaker coverage over an entire country - Denmark Emergency System.
- First comprehensive, calibrated data acquisition of sound reinforcement products.
- First integral signal-aligned three-way sound reinforcement systems - RS Series.
- First pro audio company with an Internet Web site.
- First all horn-loaded, high-fidelity, weather-resistant loudspeaker - R2 Series.

In line with our history of excellence and innovation, each Community product is manufactured in accordance with a complicated and exacting chain of procedures that ensure absolute quality.

With our unique designs, our sophisticated techniques, and our proprietary materials and transducers, we are committed to bringing only the finest audio products to the many thousands of professional sound engineers, performers, and end users who rely on them daily.



Community Professional Loudspeakers

333 East Fifth Street, Chester, PA 19013-4511 USA

Phone (610) 876-3400 • Fax (610) 874-0190

www.communitypro.com

© 2015 All Rights Reserved

TABLE OF CONTENTS

CONTENTS

EC Statement of Conformity	Page 2
Welcome to Community	Page 3
Important Safety Information	Page 5
Unpacking and Inspection	Page 6
Introduction	Page 6
Features	Page 7
Quick Start-up / Features	Page 8
Coverage Patterns	Page 10
Choosing Power Amplification	Page 12
Electrical Installation	Page 13
Connecting the Loudspeaker	Page 13
Signal Processing	Page 14
Physical Installation	Page 15
Orienting an R2	Page 16
Installing the R2 Mounting Yoke	Page 17
Maintaining Weather-Resistance	Page 20
Mechanical Installation and Safety	Page 20
Operating Precautions	Page 22
Important Installation Notes	Page 22
System Optimization	Page 23
Technical Specifications	Page 24
Wire Guide	Page 26
In Case of Difficulty	Page 27
Warranty / Service Information	Page 28

FIGURES and TABLES PAGE

Quick Start-up	Page 8
Table 1: Recommended Cable Gauge	Page 13
Chart: Recommended Effective Operating Distances	Page 16

FIGURES AND DRAWINGS

Figure 1: Physical Features	Page 9
Figure 2: R2-474 and R2-694 Asymmetrical Coverage	Page 11
Figure 3: R2 Mounting Point Loading	Page 15
Figure 4A: R2 Mounting Yoke Assembly (Exploded View)	Page 17
Figure 4B: R2 Mounting Yoke Assembly (Assembled View)	Page 18
Figure 5: R2 Dispersion	Page 25
Figure 6: R2 Wire Guide (except R2-52)	Page 26
Figure 7: R2-52 Wire Guide	Page 26

IMPORTANT SAFETY INFORMATION

IMPORTANT SAFETY INFORMATION

Always follow these basic safety precautions when using or installing R-Series loudspeakers and accessories:

Read these instructions.
Keep these instructions.
Heed all warnings.

Follow all instructions, particularly those pertaining to rigging, mounting, hanging and electrical connections. Only use accessories that are specified and approved by the manufacturer.

The terms **IMPORTANT**, **WARNING**, and **DANGER** are used throughout this manual to alert the reader to important safety considerations. If you have any questions or do not understand the meaning of these terms, do not proceed with installation. Contact your local dealer, distributor, or call Community directly for assistance. These terms are defined below:



IMPORTANT: describes an operating condition or user action that may expose the equipment or user to potential damage or danger.



WARNING: describes an operating condition or user action that will likely cause damage to the equipment or injury to the user or to others in the vicinity.



DANGER: describes an operating condition or user action that will immediately damage the equipment and/or be extremely dangerous or life threatening to the user or to others in the vicinity.

RIGGING AND ELECTRICAL SAFETY



DANGER: The loudspeakers described in this manual are designed and intended to be 'flown' or mounted or suspended for maximum acoustical performance using a variety of rigging hardware, means, and methods. Installation of loudspeakers should only be performed by trained and qualified personnel. It is strongly recommended that a licensed and certified professional structural engineer approve the mounting design. Severe injury and/or loss of life may occur if these products are improperly installed.



DANGER: R-Series rigging fittings are rated at a Working Load Limit (WLL) of 100 lbs (45.4kg) with a 10:1 safety margin. No single rigging fitting should ever be subjected to a load that is greater than this stated limit. Failure to heed this warning could result in severe injury and/or loss of life.



IMPORTANT: Refer to the sections on installation and connections later in this manual for additional information on rigging and electrical safety.



IMPORTANT: The stainless steel mounting bolts that come installed in each enclosure must either be used to mount the Accessory Mounting Yoke or they must be kept in place to seal the enclosure from air leaks. If the rigging fittings do not remain sealed, air leaks will occur in the enclosure that will compromise the loudspeaker's weather-resistance and its low frequency performance.

UNPACKING / INTRODUCTION

UNPACKING AND INSPECTION

R-Series loudspeakers are inherently rugged and are carefully packed in sturdy cartons. However, it's wise to thoroughly inspect each unit after it has been removed from the packaging, as damage could occur during shipping.

SHIPPING CLAIMS

Please note that once the shipment has left your dealer or the Community factory, the responsibility for damage is *always* borne by the freight company. If damage has occurred during shipping, you must file a claim directly with the freight company. It's very important to contact the freight company as soon as possible after receiving your shipment, as most freight companies have a short time limit within which they will investigate claims. Make sure to save the carton and the packing material, as most claims will be denied if these materials are not retained. Your Community dealer and the factory will try to help in any way they can, but *it is the responsibility of the party receiving the shipment to file the damage claim.*

It's always a good idea to retain the carton and packing materials indefinitely, if possible, in the event that the unit may need to be returned to your dealer or distributor for repair in the future.

WHAT'S IN THE BOX

Each shipping carton contains the following items:

- (1) R2 Full-Range Loudspeaker System
- 1/2—13 x 1" stainless steel mounting bolts, each with a lock, flat, and rubber washer (already installed on the enclosure)
- Mounting Yoke (Qty 1)
- Installation/Operation Manual (Qty 1)
- Warranty Card (Qty 1)

INTRODUCTION

Community's R-Series is a high-quality, high-fidelity product line designed to be highly weather-resistant. R-Series products perform consistently in continuous outdoor exposure while simultaneously providing superlative acoustic performance.

This manual is intended to help you install and use R-Series loudspeakers safely and effectively. It provides useful information to help you obtain the best performance, sound quality, and reliability from your R-Series systems. We've provided Quick-Start diagrams to enable you to install and operate the products immediately. However, we recommend that you read this manual in its entirety, to ensure that your R-Series installation meets the highest possible standards.

While every attempt has been made to ensure this information is correct and up-to-date, Community continuously incorporates worthwhile improvements to each product which may include changes and/or modifications not contained in this manual.

INTRODUCTION / FEATURES

DESCRIPTION OF THE R-SERIES

All-Weather, All-Purpose

Though designed to handle the harshest environmental conditions, R-Series is the perfect choice for many indoor environments. With 22 models to choose from, ranging from short throw with wide coverage angles to ultra-narrow, long throw systems, the task of designing an acoustically and economically effective sound system has never been easier. In many cases, a small number of R-Series loudspeakers can provide top quality sound for a surprisingly large physical area, making them one of the most acoustically and economically effective solutions available anywhere. Visit www.communitypro.com to learn more about the entire R-Series family including **R6**, **R2**, **R1**, **R.5**, **R.25**, **RSH** and **RMG** systems.

R-Series Applications

R-Series products are designed for permanent installation or portable use both outdoors and indoors. The primary applications for Community's R-Series are those where re-entrant horns, outdoor two-way horn/woofer loudspeakers, and some larger horn loudspeakers typically are used but lack capability for both high quality music reproduction and longer distance voice projection.

R-Series products are ideally suited for athletic fields (football, soccer, baseball, tennis) and field houses, theme parks, amusement parks, swimming pools, ski slopes, cruise ships, steeple carillons, fairgrounds, rodeos, small arenas, racing tracks, air shows, skating rinks, convention centers, factories, warehouses, and portable sound systems. They can complement Community WET Series II products for projects needing a combination of both longer and shorter-throw applications.

R2 FEATURES

The Community R2 loudspeakers are three-way, triaxial, full-range systems. Completely horn-loaded and with an enclosure constructed of fiberglass, they are highly weather-resistant. easy to install, and produce very high output for their size. These unique products are based around the M200 midrange driver and excel at both voice projection and full-range, high-fidelity music reproduction. These loudspeakers are very efficient, have amazing bass response, and produce high output: 130 dB SPL @ 1m. Additionally, unique coverage patterns in the R2 Series provide a range and evenness of coverage not available with conventional loudspeakers

DRIVERS

R2 loudspeakers feature a 1" exit, titanium compression driver for HF, the 2" exit M200 midrange compression driver and two 12" FerroFluid-cooled woofers. Additionally, the R2-52 loudspeaker has two M200 midrange drivers. The low frequency cones have been treated with a special water-resistant coating to make them non-hygroscopic.

CROSSOVER

The drivers are acoustically mated through a high quality three-way passive crossover using 250V mylar capacitors and precision wound coils. The crossover incorporates Community's proprietary DYNA-TECH™ protection circuitry to help prevent damage from excessive input power. The input signal to the crossover is provided through a 16-2 SJOW cable with stripped ends, held captive to the enclosure by a weather-tight gland-nut.

R2 QUICK START - FEATURES

ENCLOSURE

The R2 enclosure is made entirely of hand-laminated fiberglass. An inner low frequency fiberglass horn is bonded to the outer enclosure shell creating an air chamber between the two which forms the woofer enclosure. A separate mid-high frequency fiberglass horn is bolted into the mouth of the bass horn. All bolts and screws for mounting the enclosure and the mid/high horn assembly are stainless steel. All external mounting hardware is stainless steel. The speaker cable gland-nut is made of polypropylene and approved for outdoor electrical installation.

WEATHER-STOP™ GRILLE

Each enclosure is fitted with Community's proprietary Weather-Stop™ protective grille. The grille consists of a corrosion-resistant outer layer of perforated steel with a proprietary zinc-rich epoxy dual-layer powder coat finish in light grey, a center layer of UV-resistant reticulated foam, and an inner layer of fine-mesh screen made from a UV-resistant synthetic material that blocks rain and fights rusting. This grille assembly prevents water intrusion, while providing a high degree of acoustic transparency.

ACCESSORY

Each R2 loudspeaker includes a yoke mounting bracket. The R2 Mounting Yoke provides a convenient and robust mounting system consisting of a yoke and associated hardware to securely set the aiming angle. The yoke assembly provides a number of possible mounting scenarios as well as capability for easily orienting the aiming of the loudspeaker.

QUICK START

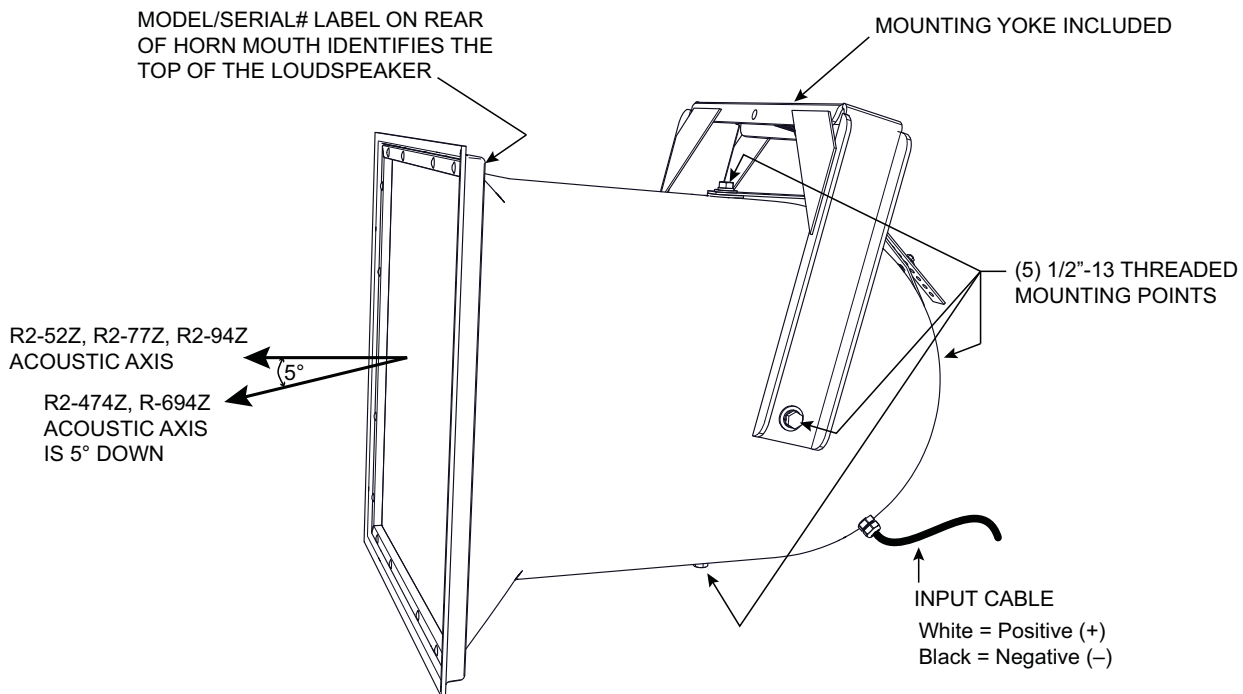

FIGURE 1A

R2 QUICK START - FEATURES

PHYSICAL FEATURES OF THE R2

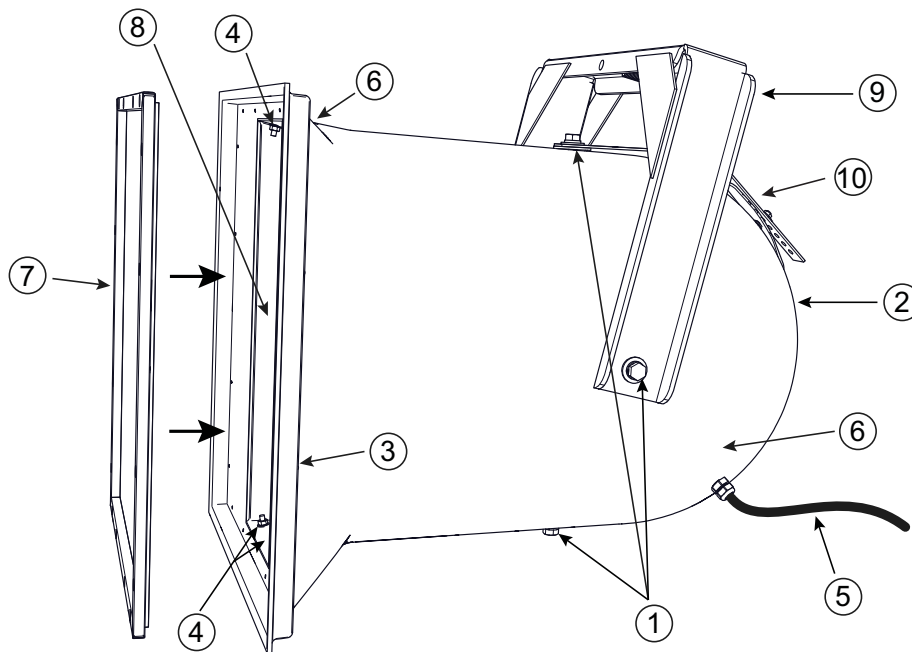

FIGURE 1B

	MOUNTING/RIGGING POINTS	DESCRIPTION
1	Mounting/Rigging Points	Five, one on each side and one on rear. 1/2"-13 captive zinc plated inserts with 1/2"-13 x 1" SS bolts and lock, flat and rubber washers. Used for attaching the R2 Mounting Yoke or customer-supplied mounting system.
Other Mounting Points		
2		
3	Grille Retainers (16)	The grille assembly is retained by (16) #6 machine screws.
4	Mid-High Frequency Horn Mounts	Two on top and bottom of horn mount. 1/4-20 x 1" SS hex head bolts. Used to attach the mid-high frequency horn assembly to the enclosure.
Input		
5	Input Cable	For signal connections to the loudspeaker. About 12 ft of 16-2 SJOW retained by a factory-sealed gland-nut. White = + and Black = -.
Other Features		
6	R2 Labels	Model number, coverage pattern, serial number, hook-up, and power information. One behind horn mouth is used to identify the top of the horn enclosure. ¹
7	Grille	Perforated steel backed by a layer of UV-resistant reticulated foam and a fine mesh screen.
8	Mid-High Frequency Horn Assembly	Mounted inside bass horn to form a triaxial system.
9	Mounting Yoke	The mounting yoke is included. See Figure 4A and 4B for assembly instructions.
10	Contour and Securing Straps	Included with mounting yoke. See Figure 4A for assembly instructions

¹ Top of enclosure is up for specified horizontal and vertical coverage.

COVERAGE PATTERNS

R2 COVERAGE PATTERNS

The coverage pattern for the particular R2 model being used must be understood for proper aiming of the loudspeaker.

ASYMMETRICAL COVERAGE PATTERN (R2-474 and R2-694 only)

The mid and high frequency horns for the R2-474 and R2-694 are unique asymmetrical designs. Their horizontal dispersion patterns are narrower in the upper part of their vertical coverage pattern and wider in the lower part. Also the vertical coverage angle is greater below the loudspeaker's geometric axis than above it (See Technical Specifications and FIGURE 5). This design has two primary benefits:

1. In the upper portion of their vertical coverage patterns, the mid and high frequencies are concentrated in a narrower beam thus effectively increasing their output there. With proper orientation, this portion of the loudspeaker's coverage pattern is used for listeners at longer distances from the loudspeaker. Because you lose 6 dB SPL for each doubling of distance, more output is needed for projecting sound over the longer distances. By contrast the lower portion of their vertical coverage patterns are spread over a wider horizontal area resulting in lower output towards the listening area nearer to the loudspeaker. This design provides more uniform sound level from the near to far listeners.
2. Because of the geometry of these asymmetrical coverage patterns, the relative width of the coverage area stays more uniform from short to long distances. This is graphically illustrated in FIGURE 2.

AIMING AXIS (R2-474 and R2-694 only)

The nominal vertical coverage patterns for the mid and high frequency section for the R2-474 and R2-694 are 15 degrees above the geometric axis of the loudspeaker and 25 degrees below it. As illustrated in the "Side View" in FIGURE 2, this means the acoustical axis of the mid and high frequencies is not the same as the geometric axis, which is perpendicular to the face of the loudspeaker. This acoustical axis is approximately 5 degrees downward when the loudspeaker is physically aimed straight ahead. This acoustical axis is used to aim the loudspeaker.

In contrast the coverage pattern of the low frequency section, for both loudspeakers, is symmetrical so its acoustical axis is the same as the geometric axis of the loudspeaker. The result is that there is relatively more low frequency energy projected above the mid and high frequency acoustical axis than below it. This better matches the low frequency output to the mid and high frequency output throughout the loudspeaker's coverage pattern.

These points should be taken into account when aiming the loudspeaker. For proper aiming, the R2-694 and R2-474 loudspeakers will be tilted down about 5 degrees *less* than a loudspeaker with a symmetrical coverage pattern.

COVERAGE PATTERNS

AIMING AXIS (All R2 models except R2-474 and R2-694)

In contrast to the R2-474 and R2-694, the other R2 models that have symmetrical coverage patterns where the geometric axis and acoustical axis are the same, the geometric axis is normally used to aim the loudspeaker.

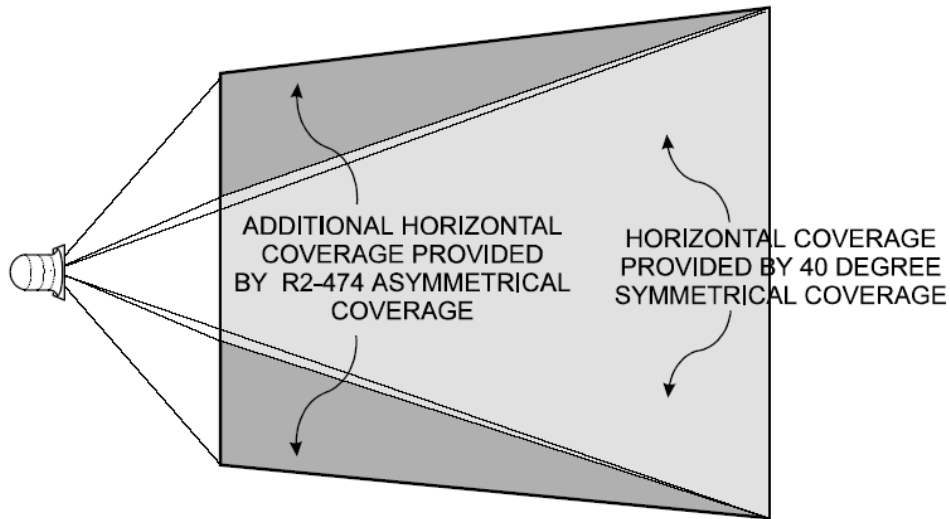

EXAMPLE "BIRD'S-EYE" VIEW
OF COVERAGE AREAS

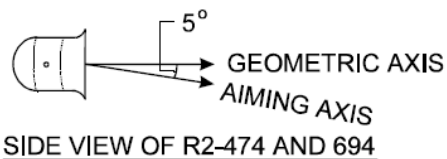

FIGURE 2: R2-474 and R2-694 Asymmetrical Coverage

NOTE: To maintain weather-resistance, the R2 cabinet should be aimed at least 15 degrees below 0° geometric axis.

POWER AMPLIFICATION

CHOOSING POWER AMPLIFICATION

Selecting a power amplifier for an R2 is straightforward. See page 14 on “High Pass Filter” and page 22 on “Limiting” for additional consideration in selecting an amplifier.

POWER RATING

The R2s are rated at 400W RMS and 1000W program power. The recommended amplifier is one with a rated RMS output from 800W to 1200W at 4 ohms. If two R2s are to be connected to one amplifier channel, use an amplifier with a rated RMS output from 1700W to 2300W at 2 ohms.

Using an amplifier of less power than recommended can result in amplifier clipping that can quickly damage the drivers. The built-in DYNA-TECH™ protection circuitry cannot detect clipping nor will it function properly when less than the recommended power is used.

Using an amplifier of more power than recommended can result in overdriving the loudspeaker with the potential for damaging the drivers and/or the protection circuitry.

DYNA-TECH™ PROTECTION CIRCUITRY

All R2s are equipped with DYNA-TECH protection circuitry built into the crossover. It is designed to provide a certain measure of protection against excessive current being delivered to the individual drivers and to the overall system. There is no external indication of when the protection circuitry is active. For this reason it is strongly recommended as an additional precaution that an external electronic limiter be used prior to the amplifier (See “Operating Precautions”, page 22).

ELECTRICAL INSTALLATION

CONNECTING THE LOUDSPEAKER

All R2s have approximately 12 ft (3.6m) of 16-2 SJOW-type neoprene jacketed cable attached to the enclosure with a weather-tight gland-nut. This is used for the input signal. This cable may be interconnected to the amplifier output cabling using solder, a terminal block, or wire-nuts. Be sure to provide the connections with a weather-resistant treatment if used outdoors. Do not remove the gland-nut that attaches the cable to the lower rear of the loudspeaker as this can compromise the weather integrity of the enclosure.

Connector Cable Polarity:

The white jacketed conductor is the positive or + signal wire and the black is the negative or – signal wire. Positive voltage applied to the + wire produces positive acoustic pressure at the mouth of the loudspeaker.

LOUDSPEAKER CABLE

The resistance of the cable you choose to go between the loudspeaker and the amplifier will affect the performance of the loudspeaker. Cable with too high a resistance can cause power losses and impair low frequency performance by reducing the electrical damping factor (DF). To minimize these kinds of losses it is desirable to keep the total cable resistance under 0.2 ohm. For lengths over 100 feet the wire gauges needed to meet this requirement are usually not practical to use for both physical and cost reasons. Therefore #10 AWG is recommended as the most practical gauge for those situations. Use TABLE 1 to select the proper wire gauge. Either stranded or solid conductors are acceptable although cable with stranded conductors can be easier to work with. The run length for both conductors has been figured into the total resistance. Note the lower the gauge number the larger the wire size.

Run Length	Minimum Gauge (AWG)	Total Resistance
10 ft. (3m)	16	0.08 ohm
25 ft. (8m)	14	0.13 ohm
50 ft. (15m)	12	0.16 ohm
75 ft. (25m)	10	0.15 ohm
100 ft. (30m)	10	0.20 ohm
200 ft. (60m)	10	0.40 ohm
300 ft. (90m)	10	0.60 ohm
400 ft. (120m)	10	0.80 ohm
500 ft. (150m)	10	1.00 ohm

Table 1: Recommended Cable Gauge

If installed outdoors, the insulation of the installer-provided cabling should be resistant to water, the effects of temperature, and the effects of ultraviolet radiation from the sun. These are recommended insulations: polyethylene, neoprene, Teflon™, Silicon™, and Hypalon™. These insulations are not recommended because of potentially shorter life expectancy in outdoor environments: rubber, PVC (polyvinylchloride), polypropylene, polyurethane, and nylon.

SIGNAL PROCESSING

HIGH-PASS (LOW FREQUENCY) FILTER

The R2s use fully horn-loaded low frequency drivers. The specified low frequency response is 70 Hz. Any attempt to reproduce significant levels below this frequency can result in over-excursion of the low frequency drivers. For this reason an electronic high-pass filter set for 60 to 70 Hz must be used. The slope should be a minimum of 12 dB per octave. This will protect the drivers from some of the extreme low frequency sounds found on CDs and other program sources. It will also protect against unwanted low frequency energy that can come from such things as microphone wind noise - an important consideration for outdoor applications.

Many power amplifier manufacturers offer plug-in high-pass filter input modules. This is an excellent method to provide the necessary filter and to make it relatively tamperproof.



IMPORTANT: Operating an R-Series loudspeaker without the recommended high pass filter will reduce its low frequency power handling and may result in physical damage to the low-frequency devices.

EQUALIZATION

The R2s are designed with a high quality crossover that acoustically balances and matches the low, mid-range, and high frequency drivers for optimum performance. However in some cases external equalization will be used to "voice" the loudspeaker for particular applications or to attenuate feedback-prone frequencies. When equalizing an R2 the following points should be kept in mind to achieve the best results and to avoid damaging the drivers.

1. Use only small amounts of equalization. In particular do not boost frequencies by more than about 3 dB. When cutting frequencies more than 3 dB of attenuation is OK. Bear in mind that extreme frequency cuts will usually result in less than optimum performance.
2. Do not attempt to boost any frequencies below 70 Hz with a graphic equalizer. Note that with the recommended high-pass filter, moderate amounts of boost from a simple bass control are acceptable.

PHYSICAL INSTALLATION

GENERAL MOUNTING INSTRUCTIONS

The R2s are equipped with five mounting points each consisting of a 1/2"-13 threaded inset. Four of the points are located at 90 degree intervals around the circumference of the body of the enclosure. They are located 16.5" (419 mm) from the back of the horn mouth flange. The fifth point is located at the apex of the rear of the enclosure bell. Each mounting point is shipped with a 1/2"-13 x 1" (25 mm) stainless steel hex head bolt, stainless steel flat and lock washers and a rubber friction/sealing washer installed. In all cases a minimum of two of the points on opposite sides of the enclosure should be used to mount or rig an R2.

ACCEPTABLE MOUNTING POINT LOADING

The mounting points should always be used so that either shear force is applied perpendicular to the direction of and in tight proximity to the mounting hole or tension force is applied perpendicular to the enclosure surface.



DANGER: Use the mounting points only as described above and shown in FIGURE 3. Do not use them in such a way as to apply sideways leverage to them. Failure to follow this instruction could result in immediate failure of the mounting points resulting in damage to the loudspeaker and serious injury or death to personnel.

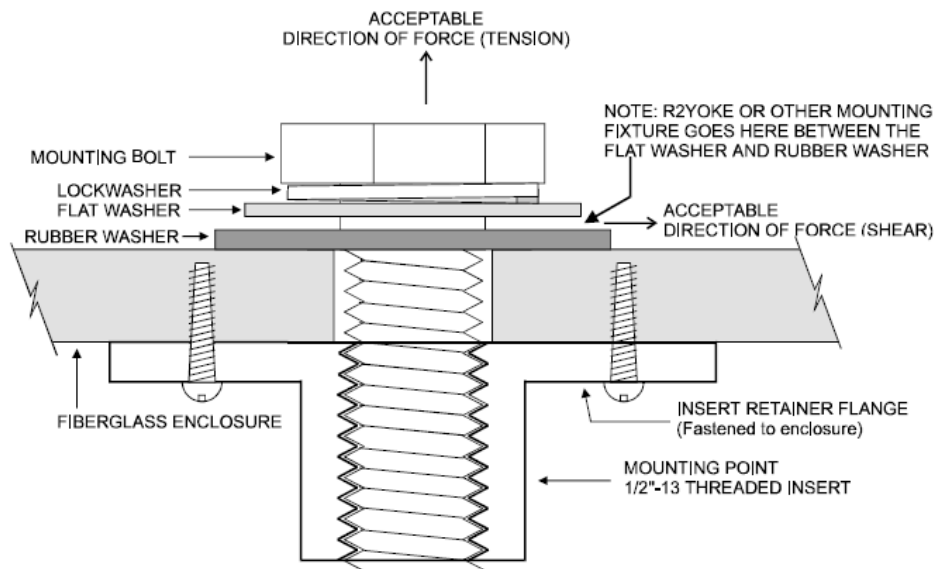

FIGURE 3: R2 Mounting Point Loading

MOUNTING OPTIONS OTHER THAN THE R2 MOUNTING YOKE

Eyebolts: A forged, load-rated, shoulder eyebolt may be used to suspend an R2. The eyebolt must be screwed in so that the shoulder firmly contacts the surface of the enclosure. In all cases the direction of pull on the eyebolt and mounting point should be in tension with up to a maximum of 30° from the vertical axis of the mounting point hole (See FIGURE 3). While a single mounting point used can support the weight of the loudspeaker with a greater than 5:1 safety factor, a safety cable that can independently support the loudspeaker must also be used. Other mounting points can be used as pull-back points to fix the aiming angle.

Custom Mounting Brackets: Custom brackets may be used. When mounting the loudspeaker the bracket should pull directly either in tension or shear on the mounting point (See FIGURE 3). It is recommended that any custom bracket be designed to utilize two mounting points on the opposite sides or top and bottom of the enclosure.

PHYSICAL INSTALLATION

ORIENTING AN R2

An R2 has a definite top and bottom. Two R2 models have asymmetrical coverage patterns (See FIGURES 2 and 5). Because of these designs, incorrect orientation will result in improper sound coverage. For the R2 models with symmetrical coverage patterns, a 180 degree inversion will not affect the coverage. When the top of the enclosure is up, the input cable gland-nut will be down and to your right when looking directly at the front of the loudspeaker. Also, the manufacturer's label is on the top of the enclosure. Once the top is determined, you can properly orient the loudspeaker for your particular application according to the specified coverage pattern.

Throw Distance and Sound Levels

The chart below helps answer the question, "how far can it throw?". The chart shows the maximum distance at which a given model can reach 96 dB SPL on the A Scale (speech range). Consider a high-school football stadium where the crowd noise is 86 dBA. At the recommended distance, an R.25 or R.5 would provide 10 dB headroom above the crowd noise. Even if the crowd noise reaches 90 dBA, the R.25 or R.5 would still provide 6 dB of headroom which is acceptable for voice paging and announcement systems (use a limiter to avoid clipping). In larger facilities, crowd noise can exceed 100 dBA. At motor racing events, racing noise can exceed 120 dBA near the track. It is impractical and unsafe to try to page above these levels. It's better to train announcers to wait until the crowd (or motor noise) quiets down and to repeat the page.



Recommended Effective Operating Distances

Reference: 96dB

Model	Description	Feet	30	40	50	60	70	80	90	100	150	190	170	180	190	200	210	220	230	240	250	300+
		Meters	9	12	15	18	21	24	27	30	46	48	52	55	58	61	64	67	70	73	76	90+
R SERIES	R.15COAX	2-way, Coaxial; LF: 1 x 6', HF: 1 x 1'	32' / 10m																			
	R.35COAX*	2-way, Coaxial; LF: 1 x 10', HF: 1 x 1.25'		52' / 16m																		
	R.25-94Z	2-way, LF: 1 x 8', HF: 1 x 1'		49' / 15m																		
	R.35-3896*	3-way; LF: 1 x 8', MF: 2 x 2.35', HF: 1 x 1'				83' / 25m																
	R.5COAX66/99**	2-way, LF: 1 x 12', HF: 1 x 1'			60' / 18m																	
	R.5-66/94/99Z**	2-way, LF: 1 x 12', HF: 1 x 1'					90' / 27m															
	R1-64,66,94**	2-way, LF: 1 x 12', HF: 1 x 1'									148' / 45m											
	R.5HP	3-way; LF: 1 x 12', MF: 1 x 2'; HF: 1 x 1'									150' / 46m											
	R.5-66/96MAX	2-way, LF: 1 x 12', HF: 1 x 1.4'									150' / 46m											
	R2-64/66/94MAX	3-way; LF: 2 x 12', MF: 1 x 2'; HF: 1 x 1.4'															205' / 61m					
	R2-52	3-way; LF: 2 x 12', MF: 2 x 2'; HF: 1 x 1'															205' / 61m					
	R2-77/94/694/474**	3-way; LF: 2 x 12', MF: 1 x 2'; HF: 1 x 1'														157' / 48m						
	R6-51BIAMP	3-way; LF: 6 x 12', MF: 6 x 2'; HF: 6 x 1'																				452' / 138m
SUBS	R.5SUB	1-way; LF: 1 x 12'	26' / 8m																			
	R2-SUBDF	1-way; LF: 2 x 12'			58' / 18m																	
	R6-BASSHORN	1-way; LF: 6 x 12'																				452' / 138m
VOICE	RMG-200A	1-way; MF: 1 x 2'																		240' / 73m		
	R.5-V2200	1-way; MF: 2 x 2'																				315' / 96m
	RSH-462	1-way; MF: 4 x 2'																				715' / 218m

96 dB SPL with no atmospheric effects
 * Voicing switch in Music position
 ** Average Max SPL considered or Max SPL of the lowest output device

For a larger view of chart, please see page 31.

PHYSICAL INSTALLATION

INSTALLING THE R2 MOUNTING YOKE

CAUTION: The R2 Mounting Yoke is specifically designed to provide a high degree of safety in R2 installations. It is highly recommended for mounting an R2. Other mounting methods should be carefully considered so that undue strain and possible failure of the mounting points does not occur.

CAUTION: In order to maintain the weather-resistant integrity of an R2, all five rubber washers supplied with the R2 mounting point hardware must be used and be flush against the enclosure when the R2 is mounted.

The yoke has three 17/32" (13.5 mm) holes in the crossbar. These holes are intended for attachment of the yoke to the structure to which the R2 is to be mounted. The hardware used for the attachment must be load-rated for the intended purpose. Also ensure that the structure you are attaching to is capable of supporting the loudspeaker and yoke assembly. This must include any torque load that may be applied to the structure as a result of the loudspeaker/yoke position and aiming angle. For outdoor installations wind loading must also be taken into account. It is recommended that a qualified and licensed structural engineer approve the mounting design.

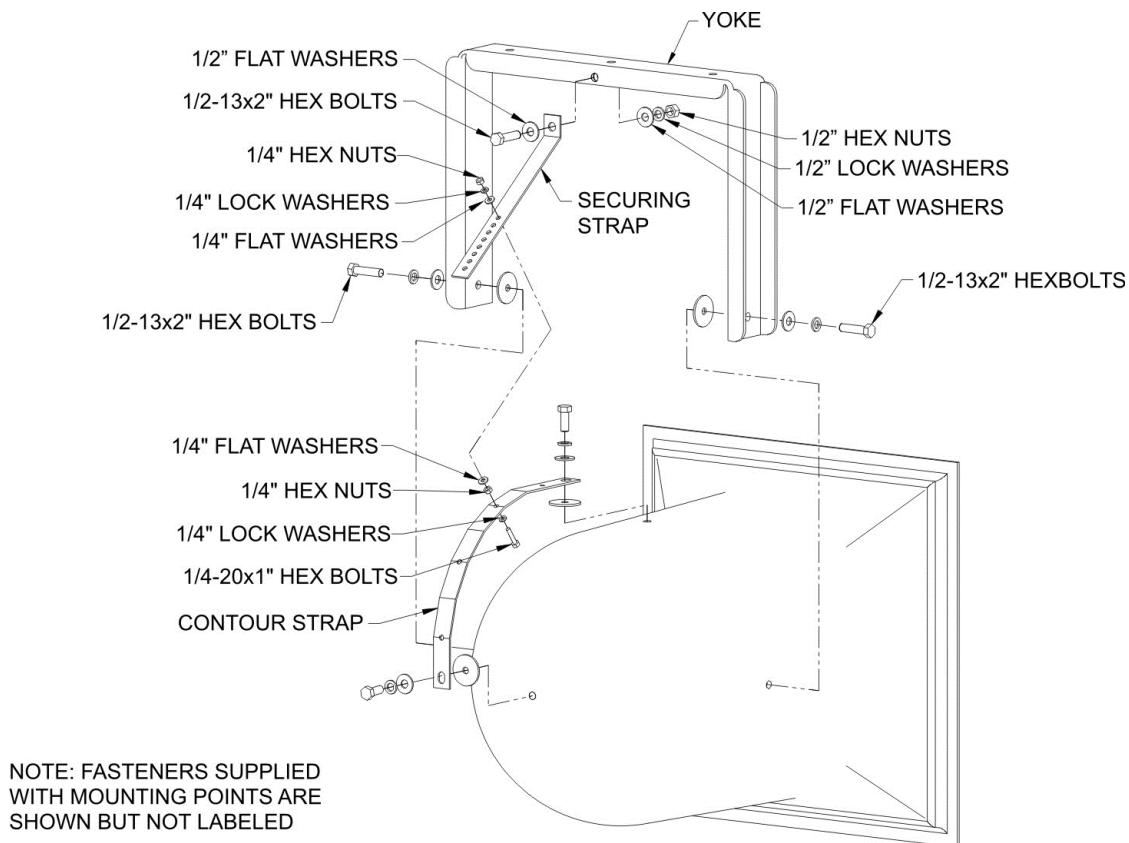

R2 YOKE ASSEMBLY: EXPLODED VIEW

Figure 4A

PHYSICAL INSTALLATION

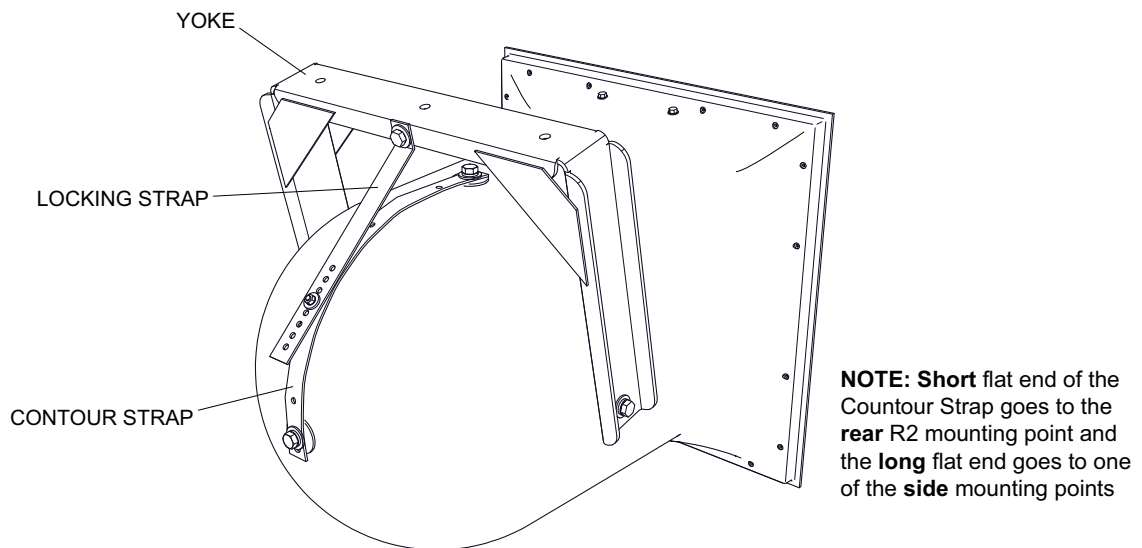

FIGURE 4B

R2 MOUNTING YOKE PARTS LIST

- (1) Yoke Bracket
- (1) Aluminum Contour Strap
- (1) Aluminum Securing Strap
- (3) 1/2-13 x 2" (50 mm) stainless steel bolts
- (1) 1/2-13 stainless steel hex nut
- (2) 1/2" stainless steel flat washers
- (1) 1/2" stainless steel lock washer
- (1) 1/4-20 x 1" (25 mm) stainless steel bolt
- (2) 1/4-20 stainless steel hex nuts
- (2) 1/4" stainless steel flat washers
- (2) 1/4" stainless steel lock washers

All other hardware must be supplied by the installer.

R2 MOUNTING YOKE ASSEMBLY INSTRUCTIONS

(SEE FIGURE 4A AND FIGURE 4B)

Normally the yoke should first be attached to the R2 then the entire assembly mounted to a structure. However in some unusual cases it may be desirable to mount the yoke and secure it in place before mounting the R2 to the yoke. Depending on the situation the sequence of the following mounting procedure may have to be modified to facilitate the work. Nonetheless the instructions and precautions about use of the hardware should still be followed.

1. To attach the yoke to the R2, first determine whether the yoke will be attached to the sides or top/bottom of the loudspeaker. This will depend on what the yoke is to be mounted to and how the R2 must be oriented when positioned for proper coverage (See "Orienting an R2", page 16).
2. Once the position of the yoke is determined, remove two supplied 1/2-13 stainless steel mounting bolts, with the lock, flat, and rubber washers from the mounting points where the yoke is to be attached.

PHYSICAL INSTALLATION

3. Position the loudspeaker within the yoke making sure that the large rubber washers sit between the yoke and the enclosure. Be aware this is intentionally made to be a tight fit. Screw the 1/2-13 x 2" (50 mm) bolts, supplied with the yoke, into the mounting holes using the rubber washers, flat washers, and lock washers removed in step two. Tighten only enough so as to allow the yoke to move as needed for the rest of the procedure. The rubber washer has a 7/16" (11 mm) hole so it fits quite snugly around the mounting bolts to form the weather seal for the R2 mounting hole. It also provides some friction to help hold the yoke in position until completely secured.
4. Attach the short flat end of the Contour Strap to the mounting point located at the back/center of the enclosure bell using the bolt, rubber washer, flat washer, and lock washer supplied in the mounting point. Make sure that the rubber washer is between the Contour Strap and the enclosure. Leave the other end (the long flat end) of the Contour Strap temporarily unattached. Eventually this will be attached to one of the side mounting points. This point must be on the side where the crossbar of the yoke will be positioned when the loudspeaker is in its final mounting location and aimed properly.
5. Mount the R2 and its attached yoke to the structure that will support it. If the center hole on the yoke crossbar is used as one of the yoke mounting points you need to attach the Securing Strap to this hole at the same time you mount the yoke to the structure that will hold the R2 assembly. In addition to attaching the Securing Strap to the yoke, the supplied stainless steel 1/2-13 x 2" bolt, 1/2" flat washers, 1/2" lock washer and 1/2-13" hex nut can be used as a yoke mounting bolt. In any case, the Securing Strap attaches to the yoke using the end of the Securing Strap with the short bent tab and the 9/16" (14 mm) hole in it. The Securing Strap tab is positioned on the side of the yoke crossbar with the long end bent towards the enclosure and positioned over the Contour Strap.
6. After properly securing the yoke to the structure, adjust the aiming angle of the R2. Once the aiming angle is set, bend the Securing Strap against the Contour Strap. The series of holes in the Securing Strap should line up with one of the three 5/16" (8 mm) holes in the Contour Strap. This determines where to locate the bolt in the Contour Strap to attach the Securing Strap. Lift the Contour Strap away from the R2 enclosure and put the 1/4-20 x 1" (25 mm) stainless steel bolt in this hole with the bolt head between the Contour Strap and the enclosure. Secure the bolt to the Contour Strap with one of the supplied 1/4" lock washers and 1/4-20 hex nuts.
7. Attach the free end of the Contour Strap to the mounting point on the side of the R2 enclosure using the 1/2" - 13 bolt, rubber washer, flat washer and lock washer supplied with the R2 mounting point. Make sure that the rubber washer is located between the Contour Strap and the enclosure.
8. Attach the Securing Strap to the 1/4-20 bolt installed on the Contour Strap in step 6. Use the hole in the Securing Strap nearest to the bolt when the R2 is at the proper aiming angle. You will have to bend the Securing Strap towards the enclosure to put it on the bolt which is normal. First place one of the 1/4" flat washers on the bolt, then the Securing Strap on the bolt. Finish with the remaining 1/4" flat washer, 1/4" lock washer then 1/4-20 nut.
9. Firmly tighten the bolts holding the yoke to the R2 enough to seat the lock washer. Be careful not to over-tighten as, given the size wrench that typically will be used, it is possible to apply excessive torque.
10. Lastly ensure that all the attachment bolts for the Contour and Securing Straps are securely tightened.



CAUTION: Any of the mounting bolts supplied with the R2 that are not used for mounting must be left in place with their rubber washers and firmly tightened to maintain the integrity of the weatherproofing.

PHYSICAL / MECHANICAL INSTALLATION

MAINTAINING WEATHER-RESISTANCE

There are several things that must be observed when installing an R2 in order to maintain its weather-resistant integrity for outdoor use.

1. We recommend **angling the R-Series loudspeaker at least 15 degrees downward** so as to reduce the possibility of rain and other precipitation compromising the performance of the loudspeaker.
2. All five mounting holes must be sealed off with the stainless steel bolts, washers, and rubber washers supplied. If, for any reason, these bolts must be removed, seal off the hole with silicone caulking or some other suitable weather-tight sealant.
3. The rubber washers supplied with the mounting bolts must always seat against the enclosure.
4. The gland-nut securing the loudspeaker cable to the enclosure is sealed at the factory. Do not attempt to remove this nut or the weather-tight seal will be broken. If it is desired to replace the gland-nut with a jack, the jack must be a weather-proof design. It must be suitably sealed to the enclosure with silicone caulk or some other suitable weather-tight sealant. The Neutrik model NL4MP is an excellent connector for this purpose. **The gland-nut should be at the bottom when mounting. Leave a “drip loop” so water will not migrate toward the loudspeaker.**
5. The grille assembly is designed to prevent normal and wind-driven rain from directly entering the mouth of the loudspeaker. The grille is not designed to withstand such things as being directly sprayed from a hose; therefore, this should be avoided.
6. If you use any hardware in place of the stainless steel screws, bolts, nuts, and washers supplied, it should also be made of stainless steel.



CAUTION: If the above instructions are not observed, the weather-resistant integrity of an R2 can be compromised. This can result in damage to or failure of the hardware or internal components which will void the warranty.

MECHANICAL INSTALLATION AND SAFETY



DANGER: The loudspeakers described in this manual are designed and intended to be ‘flown’ or suspended for maximum acoustical performance using a variety of rigging hardware, means, and methods. It is essential that all installation work involving the suspension of these loudspeaker products be performed by competent, knowledgeable persons who understand safe rigging practices. Severe injury and/or loss of life may occur if these products are improperly installed.

Important Notes on Rigging Loudspeakers

There are three areas of responsibility for rigging loudspeakers. The first is the building structure. Always consult with the building architect or structural engineer to assure the ability of the structure to support the loudspeaker system. The second area of responsibility is the loudspeaker itself. Community certifies its loudspeaker systems for suspension when they are properly installed according to our published guidelines. The third area of responsibility is everything between the loudspeaker and the building structure and the actual process of installation. The installing contractor assumes this responsibility. **Loudspeaker rigging should be performed only by certified rigging professionals using certified rigging hardware chosen for the specific application. Prior to installation, the contractor should present a rigging plan, with drawing and detailed parts list, to a licensed structural engineer (P.E.) or architect for written approval.**

MECHANICAL INSTALLATION

Using Safeties

For some applications, the installing contractor or professional engineer might deem necessary (or advisable) that R-Series cabinets be installed with a secondary means of attachment such as a safety cable. In fact, some local building codes and other regulations may require safety cables, chains or other secondary supports due to seismic concerns, excessive wind loads, etc. Be aware that safety attachment points should not be located at insert points on opposite sides of the cabinet in such a manner that they present a significant force that pulls the insert points away from each other. All safety cables, chains, or other restraining hardware shall be installed so that the line is taut and positioned to minimize dynamic loading (falling, bouncing, swinging, etc.) in the event that the loudspeaker's primary mount fails.

Community does offer in its catalog forged, rated eyebolts intended for rigging loudspeakers. However, these eyebolts are not rated for outdoor use and the shank is too long for the threaded inserts on R.25 and R.5 loudspeakers. Using an eyebolt with too long of a shank will not permit the eyebolt shoulder to properly seat against the exterior of the cabinet. Installers will need to procure appropriate hardware made from the appropriate material and shank length to meet the needs of each application.

In some cases, forged, overhead rated shoulder eyebolts may be used as attachment points on the cabinet for safety cables with some restrictions. The eyebolt must be screwed in and firmly seated (do not over tighten) with the shoulder of the eyebolt making contact with the rubber washer on the exterior of the cabinet. A rubber washer shall be used between the eyebolt and the cabinet to maintain weather-resistance. Shims may be used between the eyebolt and the rubber washer to position the eye so that it is in the same plane as the suspension cable or chain. Care must be taken to ensure that the safety cable will not induce a load off-axis from the eyebolt's threaded shank.

Hoist Rings provide a method of attachment which has advantages over eyebolts that permit more flexibility in regard to the pull/load direction of the safety line, though at a higher cost. Hoist rings include a hinged "eye" which allows the load applied to the cabinet threaded inserts to remain largely in shear, thus preserving the integrity of the insert point. The same precautions should be taken to properly seat the hoist ring as when seating an eye bolt.

As with all aspects of mounting and rigging loudspeakers, the use of eyebolts, hoist rings, and other safety cabling hardware should be included in a rigging plan approved by a professional engineer.



IMPORTANT: The mounting bolts that come installed in each R-Series enclosure must either be used to mount the Accessory Mounting Yoke or they must remain in place. If the rigging fittings are not sealed, air leaks will occur in the enclosure that will compromise the loudspeaker's weather-resistance and its low frequency performance.



IMPORTANT: Eyebolts and other mounting hardware for outdoor usage with R-Series loudspeakers must be corrosion resistant steel properly rated for the load weight.

OPERATING PRECAUTIONS

LIMITING

Community recommends use of a limiter to help prevent loudspeaker damage due to sudden transients (dropped microphones, etc.) or amplifier clipping. When used for this purpose, connect the limiter as the last item in the signal chain before the power amplifier (at the input to the power amplifier). Although R2s have built-in DYNA-TECH protection circuitry to help prevent damage to the drivers from excessive power, electronic limiting is strongly recommended. This is especially true if an R2 is installed in relatively inaccessible locations or is being operated by personnel who are not trained operators.

In such cases the limiter should be used as a hard-line device to prevent amplifier clipping and prevent output voltages in excess of 40V RMS and 95V peak power. The following are recommended settings for this purpose. Set the limiter threshold to actively limit the audio signal if the average rises above 40V. In no case should the limiting allow amplifier clipping. If adjustments are available: set the attack time to moderate time (10 msec is a good starting point) and the release time to fast (1 msec is a good starting point). This will allow most peak (dynamic) information to pass. The limiting ratio should be set to at least 10:1. Although this may compromise audio quality when limiting, you are protecting the drivers at this point and therefore audio quality should be a secondary consideration.

AMPLIFIERS WITH BUILT-IN LIMITING

Recently power amplifier manufacturers have introduced amplifiers with either built-in limiting or accessory limiting modules. In both cases these limiters are usually designed to prevent the amplifier from clipping. This type of limiting is acceptable to use in lieu of a stand-alone limiter because it is easy to set-up, is specifically designed for the amplifier, and in most cases, is tamper-proof. This assumes that the amplifier output is sized as recommended in “Choosing Power Amplification” on page 12.

SYSTEM OPTIMIZATION

CHOOSING THE RIGHT LOUDSPEAKERS AND ELECTRONICS

Choose R-Series models with high enough maximum SPL to provide the needed SPL at the farthest listener with an appropriate headroom. Typical headroom factors are at least 6 dB for voice paging, at least 10 dB for voice reinforcement and at least 20 dB for music reinforcement.

Choose R-Series models with the right frequency response for the application. Subwoofers will improve the sound quality of a music reinforcement system but may reduce intelligibility in a voice-only system in a reverberant space.

Choose R-Series models with the right coverage patterns to cover the audience evenly. Point the loudspeakers at the listeners and away from walls and ceilings or outdoor obstructions.

In outdoor applications, loudspeakers may be far enough apart to create artificial echos in areas of overlapped coverage. Ideally, put all loudspeakers in a central location (central cluster design) or use a distributed system design to minimize this problem. In any case, minimize overlap when speakers are separated by more than approximately 40 feet.

Choose power amplifiers large enough to provide the desired power output with enough headroom to avoid clipping. Use a limiter and high-pass filter to protect the loudspeakers. Follow proper wiring design and adjust gains and levels to minimize hum and noise.

COMMISSIONING THE SYSTEM

Commissioning is the process of optimizing the performance of the system after it has been installed. There are several steps in commissioning including verifying the proper operation of each system component and adjusting system gains and levels.

The last step in system commissioning is known as system equalization or “voicing”. Equalization is the process of adjusting the frequency response of the system to optimize voice intelligibility or musical sound quality (or both). Note that R-Series loudspeakers are factory voiced to optimize their speech intelligibility and musical sound quality. For this reason, many designers find they can minimize overall system equalization and still achieve excellent voice intelligibility and musical sound quality.

R2 SPECIFICATIONS*

Technical Specifications

Model:	R2-52	R2-474	R2-694	R2-77	R2-94
Loudspeaker Type:	Three-way triaxial, horn-loaded				
Frequency Response:	70 Hz to 16 kHz				
Power Handling:	400W RMS / 1000W Program (40V RMS, 89V momentary peak)				
Sensitivity 1W/1m (80 — 16 kHz):	107 dB	106 dB	104 dB	104 dB	105 dB
(250 — 4 kHz):	109 dB	107 dB	105 dB	105 dB	106 dB
Nominal Impedance:	4 ohms	4 ohms	4 ohms	4 ohms	4 ohms
Minimum:	2.7 @ 660 Hz	2.9 @ 260 Hz	2.9 @ 240 Hz	2.9 @ 270 Hz	2.9 @ 260 Hz
Crossover Points	600 Hz, 3.5 kHz	600 Hz, 3.5 kHz	600 Hz, 3.5 kHz	600 Hz, 3.5 kHz	600 Hz, 3.5 kHz
Dispersion (See Figure 5) Nominal H° x V°:	50° x 20°	40° - 70° x 40°	60° - 90° x 40°	60° x 60°	80° x 40°
Horizontal Up / Down:	50° / 50°	40° / 70°	60° / 90°	60° / 60°	80° / 80°
Vertical Up / Down:	10° / 10°	15° / 25°	15° / 25°	30° / 30°	20° / 20°
Dispersion at 400 Hz:	100° x 100°	100° x 100°	100° x 100°	100° x 100°	100° x 100°
Loudspeaker Components:					
LF	2 x12" (305 mm)	2 x12" (305 mm)	2 x12" (305 mm)	2 x12" (305 mm)	2 x12" (305 mm)
MF	2 x M200	1 x M200	1 x M200	1 x M200	1 x M200
HF	1" (51mm)	1" (51mm)	1" (51mm)	1" (51mm)	1" (51mm)
Speaker Protection:	DYNA-TECH™	DYNA-TECH™	DYNA-TECH™	DYNA-TECH™	DYNA-TECH™
Input Connection:	12 ft x 16-2 SJOW Neoprene Cable	12 ft x 16-2 SJOW Neoprene Cable	12 ft x 16-2 SJOW Neoprene Cable	12 ft x 16-2 SJOW Neoprene Cable	12 ft x 16-2 SJOW Neoprene Cable
Mounting Points:	5 x 1/2"-13 threaded inserts				
Grille:	Three-layer stainless steel WeatherStop™ grille, light grey (zinc-rich epoxy dual-layer powder coated perforated steel grille, foam, woven poly mesh)				
Accessory (Included):	Light grey, powder coated steel yoke bracket				
Dimensions (HxWxD):	24.75" (629 mm) x 24.75" (629 mm) x 30.75" (781 mm)				
Weight (without yoke)	84.5 lbs (38.3 kg)	78 lbs (35.4 kg)	78 lbs (35.4 kg)	78 lbs (35.4 kg)	78 lbs (35.4 kg)

* Community strives to improve its products on a continual basis. Specifications may therefore be subject to change without notice.

R2 SPECIFICATIONS

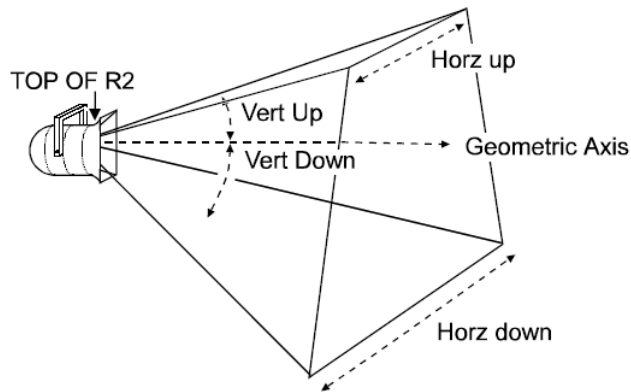
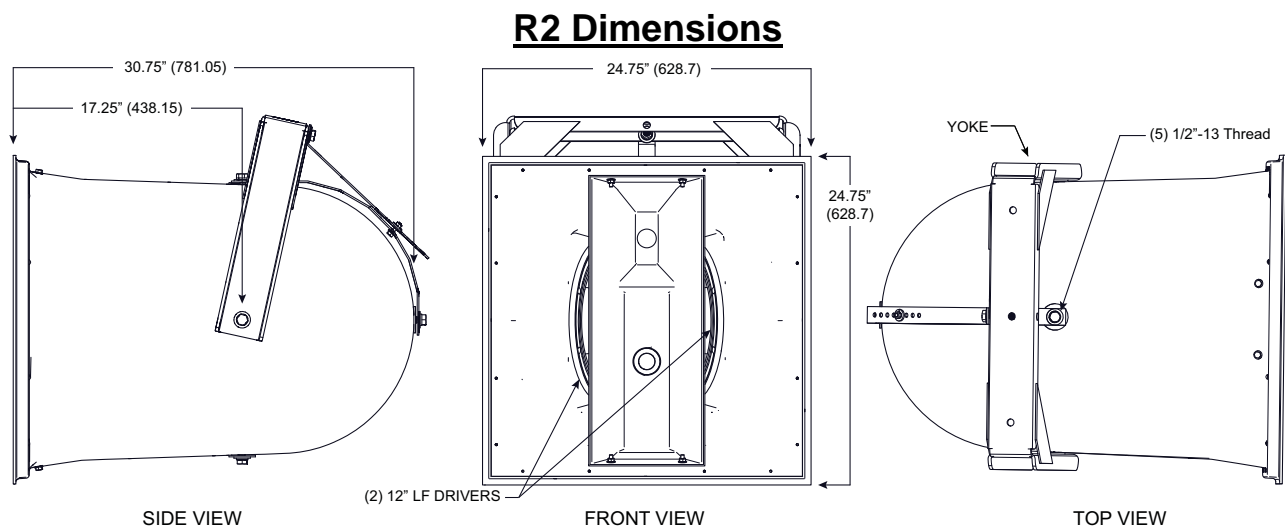
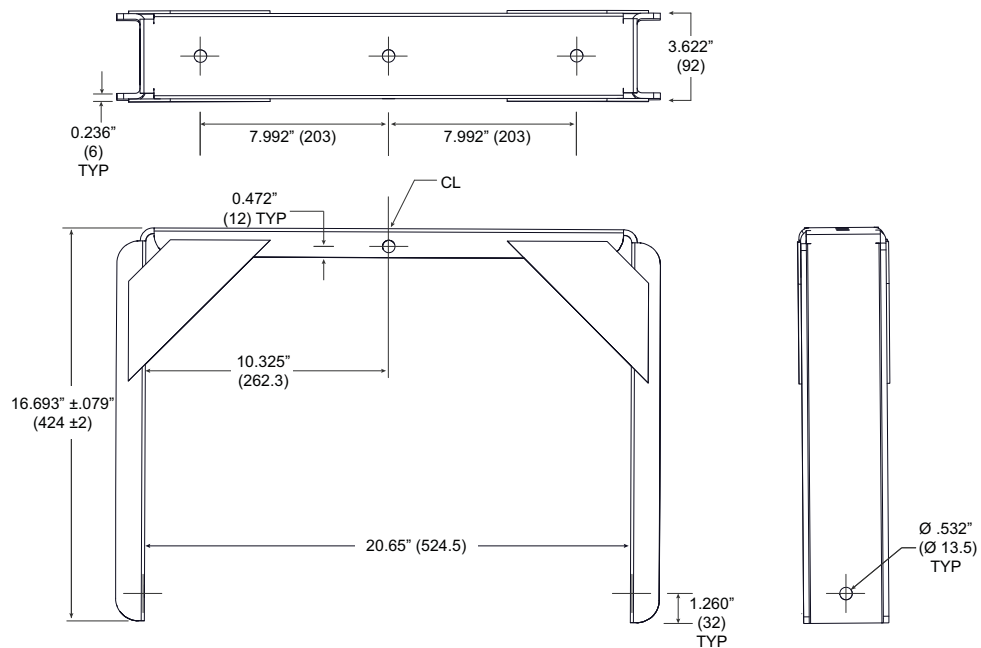

FIGURE 5: R2 DISPERSION



R2 Yoke Mounting Bracket (included)



WIRE GUIDE

R2 WIRING

MODELS R2-474Z, R2-694Z, R2-77Z AND R2-94Z

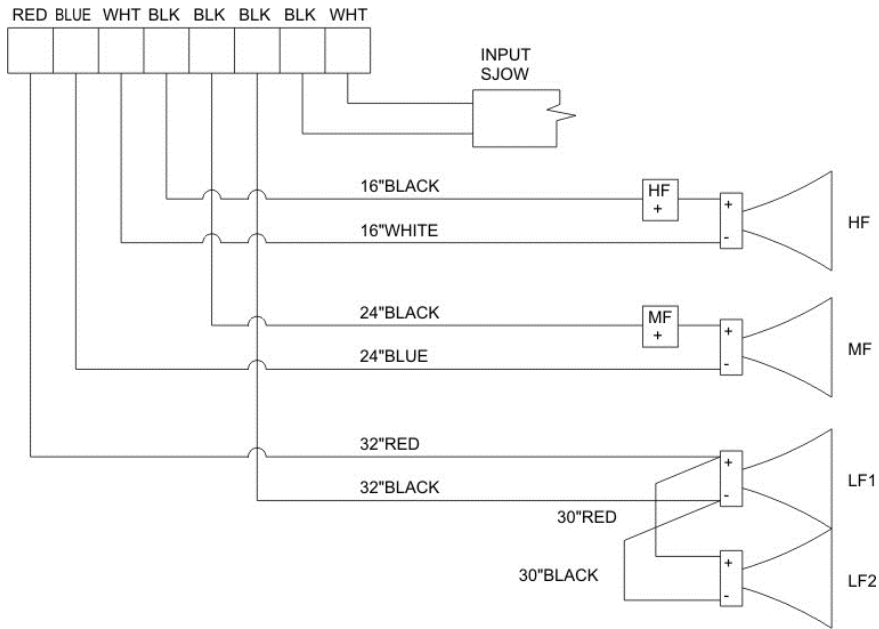

FIGURE 6: R2 Wiring (Models R2-474Z, R2-694Z, R2-77Z and R2-94Z)
 (Note: The polarity reversal shown for the MF/HF is intentional.)

MODEL R2-52Z WIRING

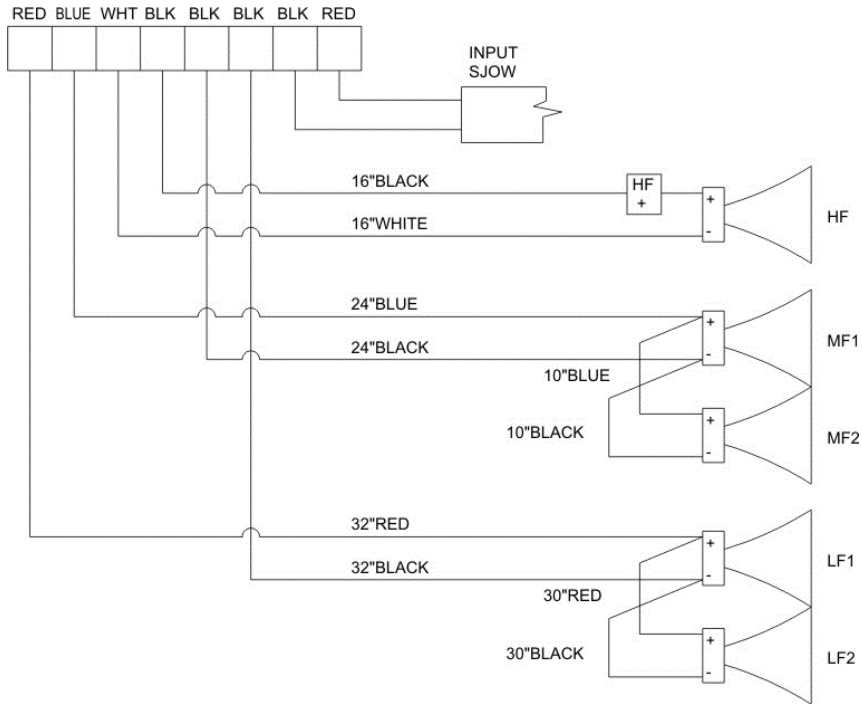

FIGURE 7: R2-52Z Wiring
 (Note: The polarity reversal shown for the HF is intentional.)

IN CASE OF DIFFICULTY

SYMPTOM	PROBABLE CAUSE	WHAT TO DO
No Sound.	Equipment is turned off.	Check and make sure that all equipment in the audio signal path is turned on. The amplifier should not be turned on until all equipment before it is turned on.
No Sound.	Bad or open connection.	Make sure the signal and input wire connections for all connectors in the system and to all terminal screws are properly connected or soldered. Make sure all wire and cables are intact and not severed or damaged.
No Sound.	Crossover or all the drivers have completely failed.	This would be an unusual cause but could occur with severe abuse or an adverse amplifier failure. All other possibilities should be explored before assuming this is the cause. If it is, replace or repair the failed components.
No sound or very low volume.	System control is turned down.	Check to make sure that the audio signal to the amplifier is high enough to drive it properly. Check all volume/level controls and gain switches in the system including the amplifier input attenuator.
Low volume level.	System electronic gain is too low.	Check to make sure that the audio signal to the amplifier is high enough to drive it properly. Check all volume/level controls and gain switches in the system including the amplifier input attenuator.
Low volume level.	Signal or speaker wire connection is shorted.	Make sure the signal and input wire connections inside all system connectors are not shorted. Even one small wire strand shorting the +/- terminals either before or after the amplifier can cause this problem.
Volume level drops and comes back.	The crossover protection circuits have been activated.	This usually means that the loudspeaker is being constantly overdriven and the crossover protection circuits are reducing the power to the loudspeaker as a protective measure, which is normal. Reduce the volume level to the loudspeaker.
Sound cuts in and out.	Bad connection.	Check all connections and cabling for shorts or loose connections.
During high output operation the volume drops suddenly and does not come back.	The crossover protection circuits have "given up".	This usually means that the loudspeaker was continually overdriven for an extended period and the protection relays have "fused" in their protect mode. The crossover must be replaced.
Distortion, low volume, or no volume from any or all drivers.	Cold/open solder joint on the crossover or faulty wiring connection.	Using an ohmmeter, check the continuity of the crimp connectors, all solder joints on the crossover and the wiring to the drivers. Also visually inspect solder joints as cold joints may only malfunction with higher current than an ohmmeter supplies. Repair as needed.
Distortion from the loudspeaker at higher volume levels.	Too little amplifier power.	If the power rating of the amplifier being used is too low, it will clip at higher volume levels. Reduce the volume level or use a more powerful amplifier equal to the loudspeaker's "Program" power rating.
Distortion from the loudspeaker at higher volume levels.	Driver is malfunctioning.	Using a sine wave oscillator or wide range program at moderate levels, listen to each driver to isolate the problem. Repair or replace as needed.
Low volume for the bass frequencies.	Low frequency driver or crossover is malfunctioning.	Using an ohmmeter, measure the resistance of the input cable (with the amplifier disconnected). If the meter reads 4–7 ohms, one driver may not be working. Replace as needed.

WARRANTY AND SERVICE

SYMPTOM	PROBABLE CAUSE	WHAT TO DO
No volume for the bass frequencies.	Low frequency driver or crossover is malfunctioning.	Using an ohmmeter, measure the resistance of the input cable (with the amplifier disconnected). If the meter does not read 1.5-3 ohms, both drivers may not be working. Repair or replace as needed.
Low or no volume for the mid frequencies.	Mid frequency driver or crossover is malfunctioning.	While right in front of the loudspeaker, listen at low level to the mid-range driver located in the middle of the horn mount. If some sound is heard and it is not distorted, it is probably a crossover problem. If distorted or no sound is heard, the driver may not be working properly. Repair or replace as needed.
Low or no volume for the high frequencies.	High frequency driver or crossover is malfunctioning.	While right in front of the loudspeaker, listen at low level to the high frequency driver located near the top of the horn mouth. If some sound is heard and it is not distorted, it is probably a crossover problem. If distorted or no sound is heard, the driver may not be working properly. Repair or replace as needed.
Noises from the loudspeaker (buzzes or rattles).	Grille or hardware is loose.	Make sure the front grille screws are firmly tightened; that any external mounting hardware is tightened or secured from vibrating (especially if chains or wires are used in the mounting).
Noises from the loudspeaker (buzzes or rattles).	Driver is malfunctioning.	Using a sine wave oscillator or wide range program at moderate levels, listen to each driver to isolate the problem. Repair or replace as needed.

FIELD SERVICE

Any driver or crossover service required is done from the front of the enclosure by removing the screws around the edge of the grille. For warranty repair, contact Community directly or ask us for the location of your nearest Authorized Service Center.

TRANSFERABLE WARRANTY "(LIMITED)" VALID IN THE USA ONLY

Community loudspeaker systems are warranted in the USA to be free from defects in materials and workmanship for a period of five years, as determined by one of the following two methods, whichever is longer:

Starting from the date of retail purchase, as noted on the sales receipt from an authorized Community dealer,

OR

Starting from the date of manufacture, determined by the serial number, if the sales receipt is not available.

This warranty applies to the product; therefore, the remainder of the warranty period will be automatically transferred to any subsequent owner.

This warranty applies only to failure of a Community loudspeaker caused by defects in materials and workmanship during the stated warranty period. It does not apply to a unit that has been subjected to abuse, accident, modification, improper handling/installation, or repairs made without factory authorization or by anyone other than authorized Community Field Service Stations. This warranty is void if the serial number has been defaced, altered or removed.

Products covered by this warranty will be repaired or replaced at the option of Community, without charge for materials or labor, provided all the terms of this warranty have been met.

WARRANTY AND SERVICE

OBTAINING WARRANTY SERVICE

Warranty service may be obtained from the factory, or from an authorized Field Service Station.

To obtain factory or field warranty service for products purchased in the United States, return the product for inspection to the address below, freight prepaid, in the original packaging. If the original packaging is not available, call or write Community Warranty Service to obtain proper packaging materials or hand carry the product to the nearest Field Service Station.

Factory Service Center:
Community Warranty Service
333 East Fifth Street
Chester, PA 19013-4511 USA

Call (610) 876-3400 for parts, service information or the nearest Authorized Field Service Station.

For factory service, please call (610) 876-3400 for a Return Authorization (R/A) number before shipping. The following information must be included in the package:

- Owner's complete name, daytime phone number, return street address and return authorization number.
- The serial number of the product being returned and a copy of the retail sales receipt, if possible.
- A complete description of the problem(s) experienced, including a brief description of how the equipment is being used and with what brand, model and output power of amplifier.

Upon receipt, the service center will determine if the problem is covered under warranty. If covered under this warranty, the product will be repaired or replaced, at Community's option, and returned to the owner freight prepaid. If the problem is not covered under this warranty, the owner will be notified of the problem with an estimate of the repair costs.

Consequential and Incidental Damages: Community shall not be liable for any consequential or incidental damages including, without limitation, injury to persons, property, or loss of use. Some states do not allow the exclusion or limitations of consequential or incidental damages, so the above limitations and exclusions may not apply.

This Community warranty is not extended by the length of time which an owner is deprived of the use of the product. Repairs and replacement parts provided under the terms of this warranty shall carry only the remaining portion of the warranty.

Community reserves the right to change the design of any product from time to time, without notice and with no obligation to make corresponding changes in products previously manufactured.

While this warranty gives specific legal rights, there may also be other rights that vary from state to state. No action to enforce this warranty shall be permitted ninety days after expiration of the warranty period.

WARRANTY INFORMATION AND SERVICE FOR COUNTRIES OTHER THAN THE USA

To obtain specific warranty information and available service locations for countries other than the United States of America, contact the authorized Community Distributor for your specific country or region.

This warranty applies only to failure of a Community loudspeaker caused by defects in materials and workmanship during the stated warranty period. It does not apply to a unit that has been subjected to abuse, accident, modification, improper handling/installation, or repairs made without factory authorization or by anyone other than authorized Community Field Service Stations. This warranty is void if the serial number has been defaced, altered or removed.

THE COMPLETE R-SERIES FAMILY

R.25

Two-way, full-range
100 Hz to 16 kHz
LF 1 x 8", HF 1 x 3/4"
200W RMS, 500W PGM, 8 ohms
Available coverage pattern: 90° x 40°

For portable systems and as short throw fill speakers.



R.5

Two-way, full-range
85 Hz to 16 kHz
LF 1 x 12", HF 1 x 1"
200W RMS, 500W PGM, 8 ohms
Available coverage patterns: 60° x 60°,
90° x 40°, 90° x 90°

*For short-to-medium throw applications like gyms
and small seating areas.*



R.5COAX

Two-way, full-range, 80 Hz to 18 kHz
LF 1 x 12", HF 1 x 1"
200W RMS, 500W PGM, 8 ohms
Available coverage patterns: 60° x 60°, 90° x 90°

*For short-throw applications such as concession
areas, gyms and as fill speakers.*



R.5HP

Three-way, full-range, 85 Hz to 16 kHz
LF 1 x 12", MF 1 x 2", HF 1 x 1"
200W RMS, 500W PGM, 6 ohms
Available coverage pattern: 60° x 40°

*For high level speech reinforcement and music
reproduction.*



R.5SUB

Subwoofer, 45 Hz to 150 Hz
LF 1 x 12"
200W RMS, 500W PGM, 6 ohms

*For near-field low frequency
reinforcement.*



R1

Two-way, full-range, 90 Hz to 16 kHz
LF 1 x 12", HF 1 x 1"
200W RMS, 500W PGM, 8 ohms
Available coverage patterns: 60° x 40°,
60° x 60°, 90° x 94°

For medium-throw indoor and outdoor applications.



R2

Three-way, full-range, 70 Hz to 16 kHz
LF 2 x 12", MF 1 x 2", HF 1 x 1"
(Model R2-52Z features MF 2 x 2")
400W RMS, 1000W PGM, 4 ohms
Available coverage patterns: 50° x 20°,
70° x 70°, 90° x 40°, 40-70° x 40°, 60-90° x 40°

*For short-to-long throw applications requiring full
bandwidth reproduction.*



R2SUB

Subwoofer, 30 Hz to 500 Hz
LF 2 x 12"
400W RMS, 1000W PGM, 4 ohms

For powerful low frequency reinforcement.



R6-51

Three-way, full-range
50 Hz to 16 kHz
LF 6 x 12", MF 6 x 2", HF 6 x 1"
LF: 1200W RMS, 4 ohms
MF: 450W RMS, 8 ohms
HF: 300W RMS, 8 ohms

*For high-level, very long throw
full-range reinforcement.*



R6-Basshorn

Basshorn 6 x 12"
45 Hz to 500 Hz
1200W RMS, 3000W PGM, 4 ohms

*For high-level, very long throw low
frequency reinforcement.*



RMG-200A

Voice-range horn system
400 Hz to 8 kHz
MF 1 x 2"
75W RMS, 120W PGM, 11 ohms

For voice-range announcement.

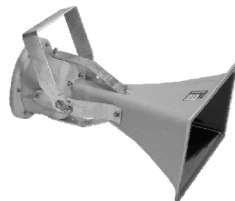

RSH-462

Exponential FocusedArray™ horn system
400 Hz to 8 kHz
MF 4 x 2"
300W RMS, 750W PGM, 11 ohms

*For voice-range announcement and
high-level paging.*



R-SERIES OPERATING DISTANCES

For an explanation of recommended effective operating distances, see page 16.

Recommended Effective Operating Distances Reference: 96dB



Model	Description	Feet		30		40		50		60		70		80		90		100		150		180		200		230		240		250		300+						
		Meters		9	12	15	18	21	24	27	30	30	46	52	55	58	61	67	70	73	76	90*																
R15COAX	2-way, Coaxial; LF: 1 x 6', HF: 1 x 1'		32' / 10m																																			
R35COAX*	2-way, Coaxial; LF: 1 x 10', HF: 1 x 1.25'			52' / 16m																																		
R25-94Z	2-way, LF: 1 x 8', HF: 1 x 1'			49' / 15m																																		
R35-3896*	3-way; LF: 1 x 8', MF: 2 x 2.35', HF: 1 x 1'				83' / 25m																																	
R5COAX66/99**	2-way, LF: 1 x 12', HF: 1 x 1'			60' / 18m																																		
R5-66/94/99Z**	2-way, LF: 1 x 12', HF: 1 x 1'					90' / 27m																																
R1-64,66,94**	2-way, LF: 1 x 12', HF: 1 x 1'									148' / 45m																												
R5HP	3-way; LF: 1 x 12', MF: 1 x 2', HF: 1 x 1'									150' / 46m																												
R5-66/96MAX	2-way; LF: 1 x 12', HF: 1 x 1.4'									150' / 46m																												
R2-64/66/94MAX	3-way; LF: 2 x 12', MF: 1 x 2', HF: 1 x 1.4'																																					
R2-5Z	3-way; LF: 2 x 12', MF: 2 x 2', HF: 1 x 1'																																					
R2-77/94/694/474**	3-way; LF: 2 x 12', MF: 1 x 2', HF: 1 x 1'																																					
R6-51BIAMP	3-way; LF: 6 x 12', MF: 6 x 2', HF: 6 x 1'																																					
R5SUB	1-way; LF: 1 x 12'																																					
R2-SUBDF	1-way; LF: 2 x 12'																																					
R6-BASSHORN	1-way; LF: 6 x 12'																																					
RMC-200A	1-way; MF: 1 x 2'																																					
R5-VZ200	1-way; MF: 2 x 2'																																					
RSH-46Z	1-way; MF: 4 x 2'																																					

96 dB SPL with no atmospheric effects
* Voicing switch in Music position
** Average Max SPL considered or Max SPL of the lowest output device



Community Professional Loudspeakers

333 East Fifth Street, Chester, PA 19013-4511 USA

Phone (610) 876-3400 • Fax (610) 874-0190

www.communitypro.com

© 2015 All Rights Reserved