

## Instruction tips to plug duplex LC patch cord in receptacles

(for M1-201SA, M1-2R2, M1-2R2VI-DU, M1-2R2H, M5-2000/200, M4-200/201)

### 1. How to plug duplex LC patch cord

**First**, safely grip the neighbor of clip mold over hook as shown in Fig. 1, not Fig.2. As shown in Fig.1, push the hook with thumb. Gripping as in Fig.2 might make the distance of two tips of fiber ferrules widen.

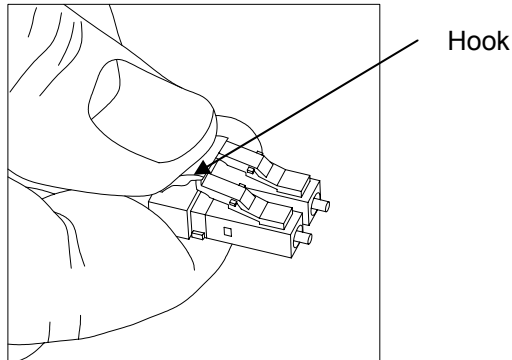

<Fig. 1>

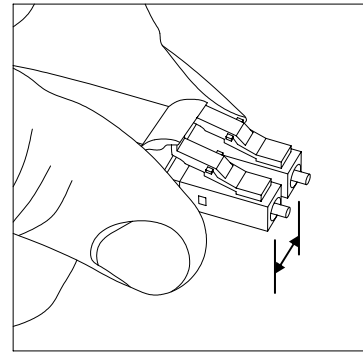

<Fig. 2>

**Second**, we recommend completing plugging with two separate steps. First, slide the duplex LC patch-cord into the receptacles until it would be positioned to be ready to insert safely, as shown in Fig. 3. Let the holders of hook of fiber ferrules safely slid while pushing down the hook as shown in Fig. 4.



<Fig. 3>

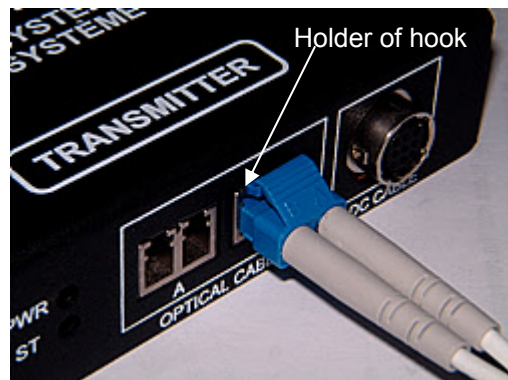

<Fig. 4>

**Third**, while keeping the grip posture with thumb as shown in Fig.1, push lightly the fiber until you could hear the hooking sound. Feeling hard for the fiber to fit in, insert the fiber while repeating to pull slightly back and push again.

### 2. How to clean contaminated fibers and optical receptacles

Whenever you get display noise in initial setting or not long-time exposure of fibers and fiber connectors to air without caps, you might doubt if some particles block lights inside receptacles or tips of fiber ferrules. In case, we

recommend you to follow the two instructions as shown in Fig. 5 and Fig. 6.

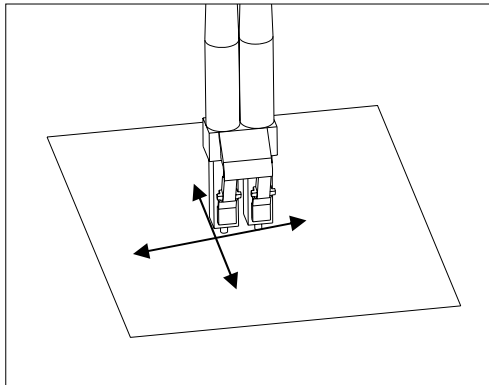

<Fig. 5>

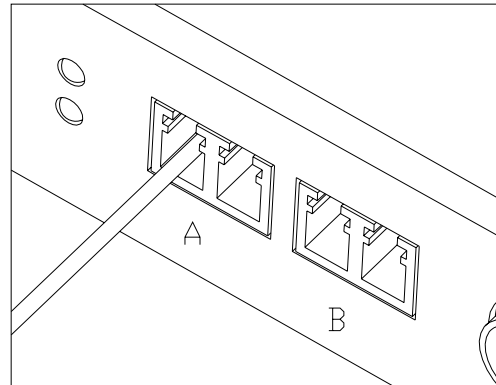

<Fig. 6>

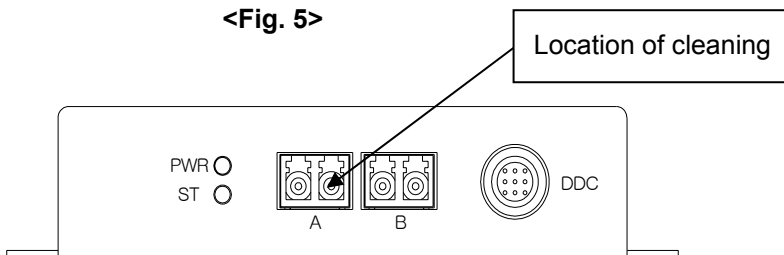

Fig 5. illustrates the dust removing of LC patch cord. Lay down the clean tissue (Approved for use of optical components) on flat table and grasp the LC duplex patch cord softly. Move the LC duplex patch cord several times on clean tissue.

Recommending clean tissue: SANTARA WIPES (2"x2" Wipe)

Fig 6. illustrates the dust removing inside optical receptacles. Insert the swab into each optical receptacle until it is no longer inserted. Rotate swab several times and pull it out.

Recommending swab: USCONEC #6365 (1.25mm swab)