

Kramer Electronics, Ltd.

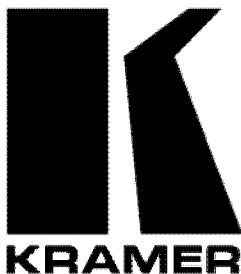

USER MANUAL

Models:

703xl, Quad Video Line Transmitter

705xl, Dual Video Line Transmitter

706xl, Dual Output Video Line Receiver

Contents

1	Introduction	1
2	Getting Started	1
3	Overview	1
4	Video Line Transmitter and Output Video Line Receiver	3
5	Connecting a Video Line Transmitter/ Receiver System	5
5.1	Connecting a Dual Video Line Transmitter/ Receiver System	6
5.2	Connecting a Quad Video Line Transmitter/ Receiver System	8
6	Technical Specifications	10

Figures

Figure 1:	703xl Quad Video Line Transmitter	3
Figure 2:	705xl Dual Video Line Transmitter	4
Figure 3:	706xl Dual Output Video Line Receiver	5
Figure 4:	705xl Dual Video Line Transmitter / Receiver System	7
Figure 5:	703xl Quad Video Line Transmitter / Receiver System	9

Tables

Table 1:	Front Panel 703xl Quad Video Line Transmitter Features	3
Table 2:	Rear Panel 703xl Quad Video Line Transmitter Features	3
Table 3:	705xl Dual Video Line Transmitter Features	4
Table 4:	706xl Dual Output Video Line Receiver Features	5
Table 5:	Technical Specifications of the 703xl / 705xl / 706xl	10

1 Introduction

Dedication by Kramer Electronics since 1981, to the development and manufacture of high quality video/audio equipment, makes the Kramer line an integral part of the finest production and presentation facilities in the world. In recent years, Kramer has redesigned and upgraded most of the line, making the best even better! The Kramer line of professional video/audio electronics is one of the most versatile and complete available, and is a true leader in terms of quality, workmanship, price/performance ratio and innovation.

In addition to our high quality twisted-pair interfaces, like the **703xl Quad Video Line Transmitter**, the **705xl Dual Video Line Transmitter**, and the **706xl Dual Output Video Line Receiver**, we also offer excellent switchers and matrices, distribution amplifiers, presentation processors, remote controllers and computer-related products.

Congratulations on purchasing your Kramer **703xl Quad Video Line Transmitter**, **705xl Dual Video Line Transmitter** and/or **706xl Dual Output Video Line Receiver**. These products are ideal for:

- Simplification of security and CCTV installations
- Presentation and other wall-plate mounted systems
- Simple and quick studio wiring

The package includes the following items:

- **703xl, Quad Video Line Transmitter** and/or **705xl, Dual Video Line Transmitter** and/or **706xl, Dual Output Video Line Receiver**
- Power adapters(s)
- This user manual¹ and the Kramer concise product catalog/CD

2 Getting Started

We recommend that you:

- Unpack the equipment carefully and save the original box and packaging materials for possible future shipment
- Review the contents of this user manual

3 Overview

Using a *Video Line Transmitter* with a **706xl Dual Output Video Line**

¹ Download up-to-date Kramer user manuals from the Internet at this URL: <http://www.kramerelectronics.com/manuals.html>

*Receiver*¹ constitutes a video line transmitter / receiver system. With the **706xl**:

- UTP (unshielded twisted pair) wiring is recommended
- Using good quality cable, the system can maintain the bandwidth of an industrial color video signal up to 1000 meters, and a broadcast quality signal (as high as 12 MHz) up to 300 meters
- A bandwidth of 30 MHz is easily achievable at shorter distances
- Kramer twisted pair adapters are an excellent way to solve remote monitoring requirements without using more costly coaxial cable or fiber, or wireless transmission systems

A choice of 2 video line transmitters is available:

- **703xl** *Quad Video Line Transmitter*
- **705xl** *Dual Video Line Transmitter*

Both the **703xl** and the **705xl** work in conjunction with the **706xl** receiver as a high performance set, designed to transmit composite video signals over long distances using common twisted pair cable.

The **703xl** Quad Video Line Transmitter includes:

- 4 independent twisted pair outputs derived from 4 looped-through video inputs
- Individual gain control and cable equalization (EQ.) control for each output

The **705xl** Dual Video Line Transmitter includes:

- 2 independent twisted pair outputs derived from a single, looped-through video input
- Individual gain control and cable EQ. control for each output, for 2 separate, simultaneous paths of operation; or for two sets of twisted pair (TP) wires

Achieving the best performance means:

- Connecting only good quality connection cables, thus avoiding interference, deterioration in signal quality due to poor matching, and elevated noise levels (often associated with low quality cables)
- Avoiding interference from neighboring electrical appliances that may adversely influence signal quality and positioning your *Video Line Transmitter* and/or a **706xl** *Dual Output Video Line Receiver* in a location free from moisture and away from excessive sunlight and dust

¹ Its loop through input with a termination switch allows for branching

4 Video Line Transmitter and Output Video Line Receiver

Figure 1, Table 1 and Table 2 define the **703xl Quad Video Line Transmitter**:

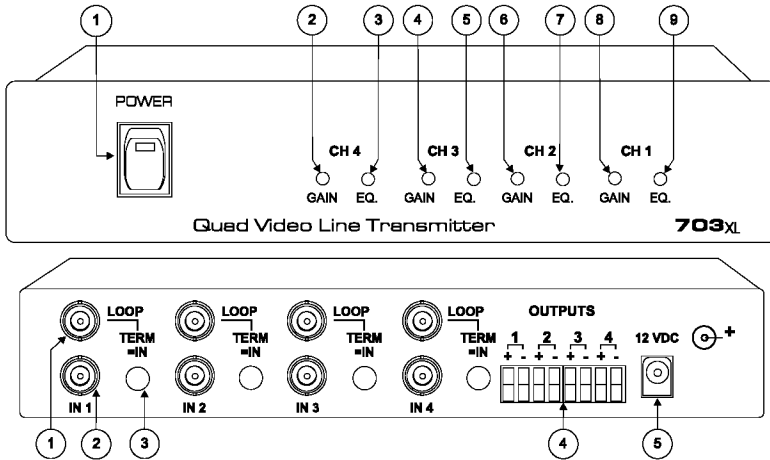

Figure 1: 703xl Quad Video Line Transmitter

Table 1: Front Panel 703xl Quad Video Line Transmitter Features

#	Feature	Function	
1	POWER Switch	Illuminated switch supplying power to the unit	
2	CH 4	GAIN Trimmer	Adjusts ¹ the output signal level for output 4
3		EQ. Trimmer	Adjusts ¹ the cable compensation equalization level for output 4
4	CH 3	GAIN Trimmer	Adjusts ¹ the output signal level for output 3
5		EQ. Trimmer	Adjusts ¹ the cable compensation equalization level for output 3
6	CH 2	GAIN Trimmer	Adjusts ¹ the output signal level for output 2
7		EQ. Trimmer	Adjusts ¹ the cable compensation equalization level for output 2
8	CH 1	GAIN Trimmer	Adjusts ¹ the output signal level for output 1
9		EQ. Trimmer	Adjusts ¹ the cable compensation equalization level for output 1

Table 2: Rear Panel 703xl Quad Video Line Transmitter Features

#	Feature	Function
1	LOOP BNC Connectors (1 to 4)	For looping (if required) the input sources
2	IN BNC Connectors (1 to 4)	Connects to the composite video sources
3	TERM=IN Buttons (1 to 4)	Pushing in selects 75 Ω ; releasing selects Hi-Z ²
4	OUTPUTS Terminal Block Connectors (1 to 4)	Connect an output to an IN connector on a 706xl Dual Output Video Line Receiver ³
5	12 VDC	+12V DC connector for powering the unit

1 Insert a screwdriver into the hole and carefully rotate it, to trim the level

2 For looping select Hi-Z

3 See Figure 5

Figure 2 and Table 3 define the **705xl Dual Video Line Transmitter**:

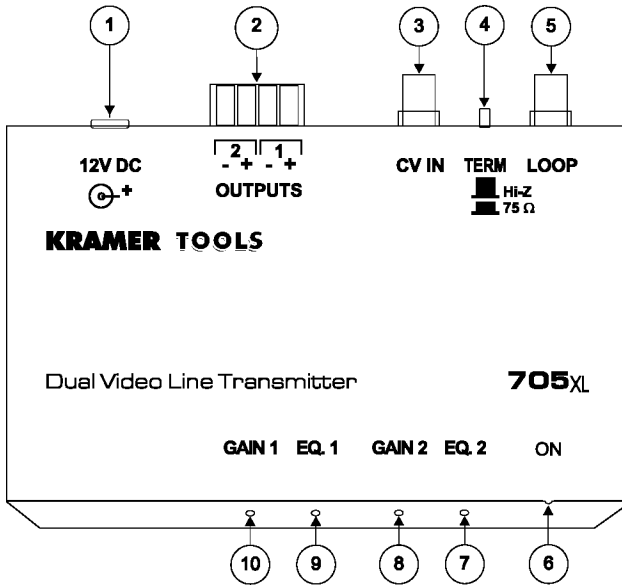

Figure 2: 705xl Dual Video Line Transmitter

Table 3: 705xl Dual Video Line Transmitter Features

#	Feature	Function
1	12 VDC	+12V DC connector for powering the unit
2	OUTPUTS Terminal Block Connectors (1 to 2)	Connect an output to an <i>IN</i> connector on a 706xl Dual Output Video Line Receiver ¹
3	CV IN BNC Connectors	Connects to the composite video source
4	TERM Button	Pushing in selects 75Ω; releasing selects Hi-Z ²
5	LOOP BNC Connectors	For looping (if required) the input sources
6	ON LED	Illuminates when receiving power
7	EQ. 2 Trimmer	Adjusts ³ the cable compensation equalization level for output 2
8	GAIN 2 Trimmer	Adjusts ³ the output signal level for output 2
9	EQ. 1 Trimmer	Adjusts ³ the cable compensation equalization level for output 1
10	GAIN 1 Trimmer	Adjusts ³ the output signal level for output 1

Figure 3 and Table 4 define the **706xl Dual Output Video Line Receiver**:

1 See Figure 4

2 For looping select Hi-Z

3 Insert a screwdriver into the hole and carefully rotate it, to trim the level

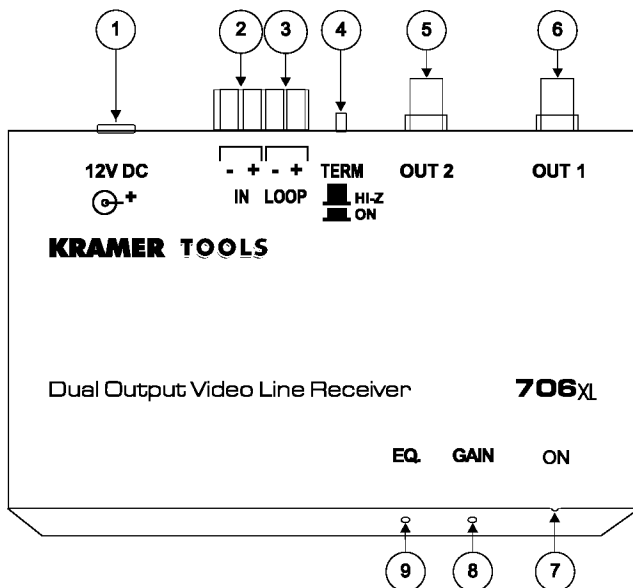

Figure 3: 706xl Dual Output Video Line Receiver

Table 4: 706xl Dual Output Video Line Receiver Features

#	Feature	Function
1	12 VDC	+12V DC connector for powering the unit
2	IN Terminal Block Connector	Connects to an output connector on a 705xl Dual Video Line Transmitter or on a 703xl Quad Video Line Transmitter
3	LOOP Terminal Block Connector	For looping (if required) the TP line
4	TERM Button	Pushing in terminates TP line; releasing selects <i>Hi-Z</i> ¹
5	OUT 2 BNC Connector	Connects to the composite video acceptor 2
6	OUT 1 BNC Connector	Connects to the composite video acceptor 1
7	ON LED	Illuminates when receiving power
8	GAIN Trimmer	Adjusts ² the output signal level
9	EQ. Trimmer	Adjusts ² the cable compensation equalization level

5 Connecting a Video Line Transmitter/ Receiver System

Sections 5.1 and 5.2 describe how to connect a dual video line transmitter/ receiver system, and a quad video line transmitter/ receiver system, respectively.

¹ For looping select Hi-Z

² Insert a screwdriver into the hole and carefully rotate it, to trim the level

5.1 Connecting a Dual Video Line Transmitter/ Receiver System

To configure a *Dual Video Line Transmitter / Dual Output Video Line Receiver* system, using two **705xl** units and four **706xl** units, as Figure 4 illustrates, do the following:

1. Connect a composite video source (for example, a VCR) to the *CV IN* BNC connector on the first **705xl** unit and release the TERM button to Hi-Z.
2. Connect the first **705xl** unit's *LOOP* connector to the *CV IN* connector on the second **705xl** unit and push in the Term button (on the second **705xl** unit) to 75Ω.
3. Connect the first **705xl** unit's *OUTPUT 1* terminal block connectors to the *IN* terminal block connectors on the "A1, A2" **706xl** unit¹.
4. Connect the first **705xl** unit's *OUTPUT 2* terminal block connectors to the *IN* terminal block connectors on the "B1, B2" **706xl** unit¹.
5. Connect the "A1, A2" **706xl** unit's *LOOP* terminal block connectors to the *IN* terminal block connectors on the "A3, A4" **706xl** unit¹. This creates transceiver connection A.
6. Connect the "B1, B2" **706xl** unit's *LOOP* terminal block connectors to the *IN* terminal block connectors on the "B3, B4" **706xl** unit¹. This creates transceiver connection B.
7. Connect the composite video outputs on up to four pairs of **706xl** units to their respective composite video acceptors, as follows:
 - On the "A1, A2" unit, OUT 1 to acceptor 1A; OUT 2 to acceptor 2A
 - On the "B1, B2" unit, OUT 1 to acceptor 1B; OUT 2 to acceptor 2B
 - On the "A3, A4" unit, OUT 1 to acceptor 3A; OUT 2 to acceptor 4A
 - On the "B3, B4" unit, OUT 1 to acceptor 3B; OUT 2 to acceptor 4B
8. Connect the power adapter on each unit to the electricity supply.
9. Adjust the output signal level and the cable compensation equalization level individually, for each output, if required.

¹ Connect "+" to "+", and "-" to "-" between the terminal block connectors

Connecting a Video Line Transmitter/ Receiver System

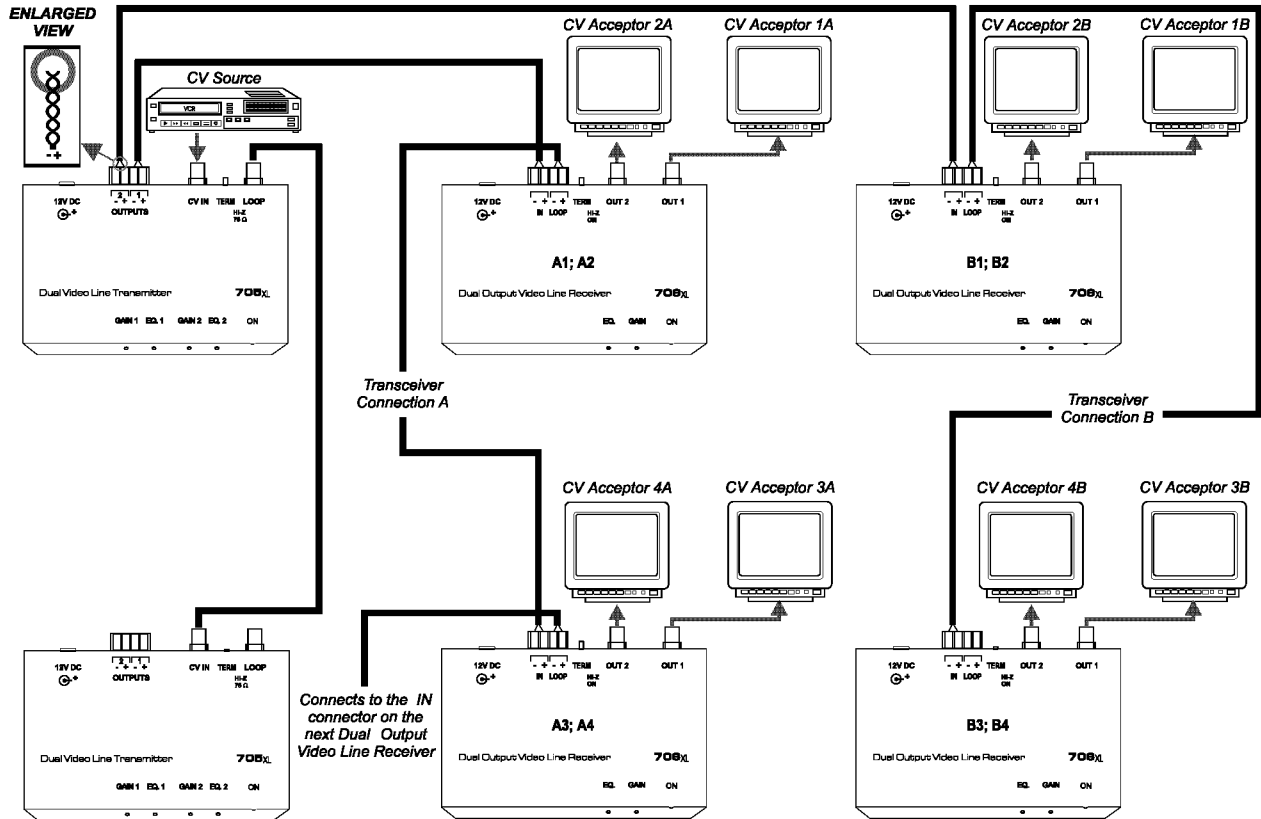

Figure 4: 705xl Dual Video Line Transmitter / Receiver System

5.2 Connecting a Quad Video Line Transmitter/ Receiver System

To configure a *Quad Video Line Transmitter / Dual Output Video Line Receiver* system, using a **703xl** unit and up to four **706xl** units, as Figure 5 illustrates, do the following:

1. Connect up to 4 composite video sources (for example, 4 VCRs) to the 4 *IN* BNC connectors on the **703xl** unit.
2. Connect up to 4 of the **703xl** unit's *OUTPUT* terminal block connectors to the respective *IN* terminal block connectors¹ on each of the four **706xl** units ("A1, A2", "B1, B2", "C1, C2", and "D1, D2")².
3. Connect the "A1, A2" **706xl** unit's *LOOP* terminal block connectors to the *IN* terminal block connectors on the "A3, A4" **706xl** unit¹. This creates transceiver connection A.
4. Repeat step 3 (above) connecting up to 3 additional pairs of **706xl** units¹. This creates transceiver connections B ("B1, B2" to "B3, B4"), C ("C1, C2" to "C3, C4"), and D ("D1, D2" to "D3, D4").
5. Connect the composite video outputs on up to four pairs of **706xl** units to their respective composite video acceptors, as follows:
 - On the "A1, A2" unit, OUT 1 to acceptor 1A; OUT 2 to acceptor 2A
 - On the "B1, B2" unit, OUT 1 to acceptor 1B; OUT 2 to acceptor 2B
 - On the "A3, A4" unit, OUT 1 to acceptor 3A; OUT 2 to acceptor 4A
 - On the "B3, B4" unit, OUT 1 to acceptor 3B; OUT 2 to acceptor 4B
 - On the "C1, C2" unit, OUT 1 to acceptor 1C; OUT 2 to acceptor 2C
 - On the "D1, D2" unit, OUT 1 to acceptor 1D; OUT 2 to acceptor 2D
 - On the "C3, C4" unit, OUT 1 to acceptor 3C; OUT 2 to acceptor 4C
 - On the "D3, D4" unit, OUT 1 to acceptor 3D; OUT 2 to acceptor 4D
6. Connect the power adapter on each unit to the electricity supply.
7. Adjust the output signal level and the cable compensation equalization level individually, for each output, if required.

¹ Connect "+" to "+", and "-" to "-" between the connectors

² Figure 5 shows OUTPUTS 1 and 4 connected to the IN on 706xl units, "A1, A2" and "D1, D2", respectively

Connecting a Video Line Transmitter/ Receiver System

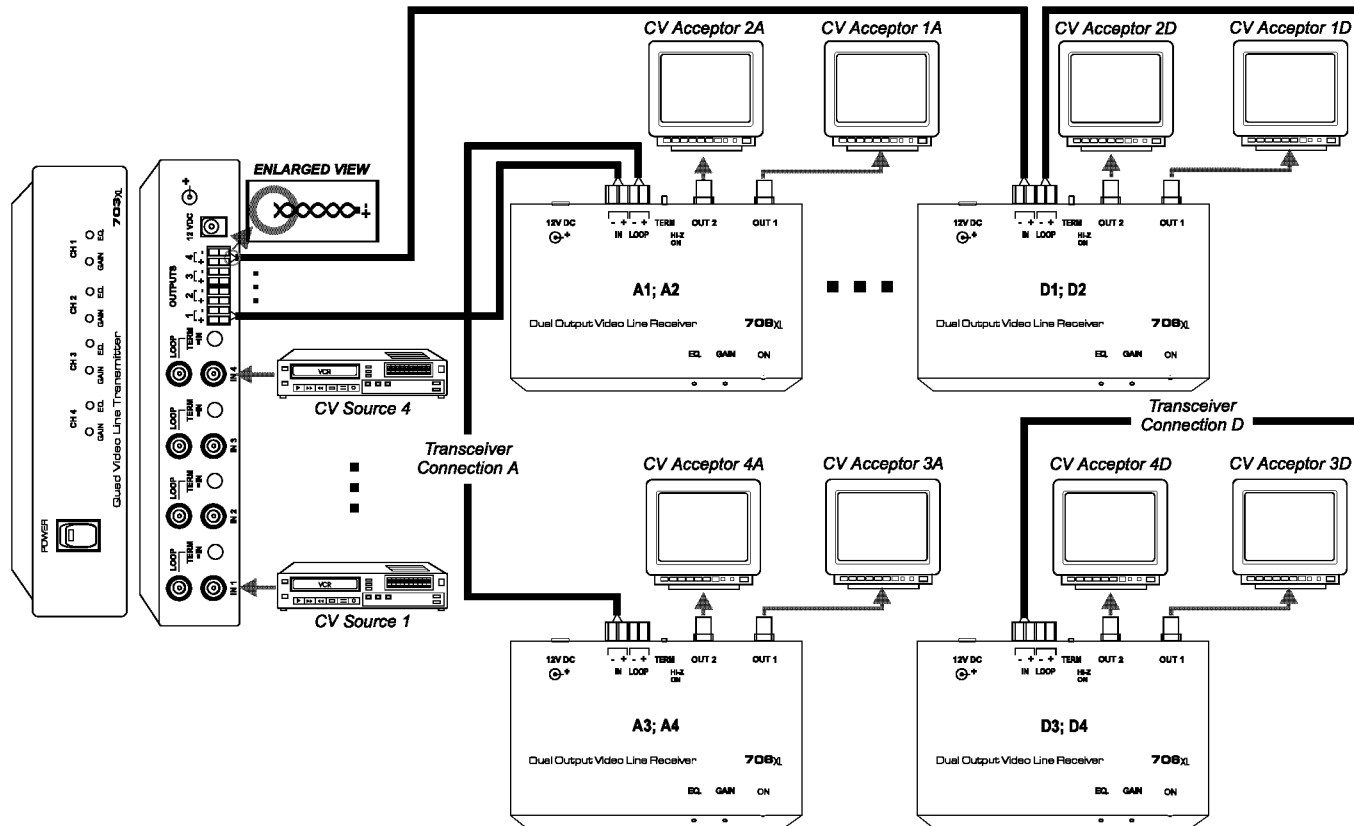

Figure 5: 703xl Quad Video Line Transmitter / Receiver System

6 Technical Specifications

Table 5 defines the technical specifications¹ of the **703xl / 705xl / 706xl** (using 100m UTP cable, unless stated otherwise):

Table 5: Technical Specifications of the 703xl / 705xl / 706xl

INPUTS:	703xl: 4 composite video 1Vpp/75Ω on BNC connectors; 4 Loop 1Vpp/75Ω on BNC connectors 705xl: 1 composite video 1Vpp/75Ω on a BNC connector; 1 Loop 1Vpp/75Ω on a BNC connector 706xl: 1 input on terminal block connectors; 1 Loop on terminal block connectors
OUTPUTS:	703xl: 4 terminal block connectors 705xl: 2 terminal block connectors 706xl: 2 composite video 1Vpp/75Ω on BNC connectors
BANDWIDTH (-3dB):	(Industrial color video signal) at a distance of 1000 meters Up to 12 MHz -3dB (broadcast quality signal) at a distance of 300 meters 53 MHz -3dB at a distance of 100 meters
DIFF. GAIN (Pair):	0.08%
DIFF. PHASE (Pair):	0.07 Deg
K-FACTOR (Pair):	3.1%
S/N RATIO (Pair):	57dB
GAIN (EQ.):	0 to 3.5dB @ 5MHz
COUPLING:	DC
POWER SOURCE:	12 VDC, 200mA
DIMENSIONS:	703xl: 22cm x 18cm x 4.5 cm (8.7" x 7" x 1.7") W, D, H (half 19", 1U)
	705xl/706xl: 12 cm x 7.5 cm x 2.5 cm (4.7" x 2.95" x 0.98", W, D, H)
WEIGHT:	703xl: 1.2 kg. (2.65 lbs.) approx.
	705xl/706xl: 0.3 kg (0.66 lbs.) approx.
ACCESSORIES:	Power supply, mounting bracket
OPTIONS:	19" rack adapter RK-80

¹ Specifications are subject to change without notice

LIMITED WARRANTY

Kramer Electronics (hereafter *Kramer*) warrants this product free from defects in material and workmanship under the following terms.

HOW LONG IS THE WARRANTY

Labor and parts are warranted for three years from the date of the first customer purchase.

WHO IS PROTECTED?

Only the first purchase customer may enforce this warranty.

WHAT IS COVERED AND WHAT IS NOT COVERED

Except as below, this warranty covers all defects in material or workmanship in this product. The following are not covered by the warranty:

1. Any product which is not distributed by Kramer, or which is not purchased from an authorized Kramer dealer. If you are uncertain as to whether a dealer is authorized, please contact Kramer at one of the agents listed in the web site www.kramerelectronics.com.
2. Any product, on which the serial number has been defaced, modified or removed.
3. Damage, deterioration or malfunction resulting from:
 - i) Accident, misuse, abuse, neglect, fire, water, lightning or other acts of nature
 - ii) Product modification, or failure to follow instructions supplied with the product
 - iii) Repair or attempted repair by anyone not authorized by Kramer
 - iv) Any shipment of the product (claims must be presented to the carrier)
 - v) Removal or installation of the product
 - vi) Any other cause, which does not relate to a product defect
 - vii) Cartons, equipment enclosures, cables or accessories used in conjunction with the product

WHAT WE WILL PAY FOR AND WHAT WE WILL NOT PAY FOR

We will pay labor and material expenses for covered items. We will not pay for the following:

1. Removal or installations charges.
2. Costs of initial technical adjustments (set-up), including adjustment of user controls or programming. These costs are the responsibility of the Kramer dealer from whom the product was purchased.
3. Shipping charges.

HOW YOU CAN GET WARRANTY SERVICE

1. To obtain service on you product, you must take or ship it prepaid to any authorized Kramer service center.
2. Whenever warranty service is required, the original dated invoice (or a copy) must be presented as proof of warranty coverage, and should be included in any shipment of the product. Please also include in any mailing a contact name, company, address, and a description of the problem(s).
3. For the name of the nearest Kramer authorized service center, consult your authorized dealer.

LIMITATION OF IMPLIED WARRANTIES

All implied warranties, including warranties of merchantability and fitness for a particular purpose, are limited in duration to the length of this warranty.

EXCLUSION OF DAMAGES

The liability of Kramer for any effective products is limited to the repair or replacement of the product at our option. Kramer shall not be liable for:

1. Damage to other property caused by defects in this product, damages based upon inconvenience, loss of use of the product, loss of time, commercial loss; or
2. Any other damages, whether incidental, consequential or otherwise. Some countries may not allow limitations on how long an implied warranty lasts and/or do not allow the exclusion or limitation of incidental or consequential damages, so the above limitations and exclusions may not apply to you.

This warranty gives you specific legal rights, and you may also have other rights, which vary from place to place.

NOTE: All products returned to Kramer for service must have prior approval. This may be obtained from your dealer.

This equipment has been tested to determine compliance with the requirements of:

EN-50081:	"Electromagnetic compatibility (EMC); generic emission standard. Part 1: Residential, commercial and light industry"
EN-50082:	"Electromagnetic compatibility (EMC) generic immunity standard. Part 1: Residential, commercial and light industry environment".
CFR-47:	FCC Rules and Regulations: Part 15: "Radio frequency devices Subpart B – Unintentional radiators"

CAUTION!

- ☒ Servicing the machines can only be done by an authorized Kramer technician. Any user who makes changes or modifications to the unit without the expressed approval of the manufacturer will void user authority to operate the equipment.
- ☒ Use the supplied DC power supply to feed power to the machine.
- ☒ Please use recommended interconnection cables to connect the machine to other components.



For the latest information on our products and a list of Kramer distributors, visit our Web site: www.kramerelectronics.com.

**Updates to this user manual may be found at
<http://www.kramerelectronics.com/manuals.html>.**

We welcome your questions, comments and feedback.

Kramer Electronics, Ltd.

3 Am VeOlamo Street, Jerusalem 95463, Israel Tel: (+972 2) 654 4000

Fax: (+972 2) 653 5369, E mail: info@kramerelect.com

P/N: 2900 005006 REV 1